

CANOSCAN

D1230/D2400

SERIES

SERVICE

MANUAL

REVISION 0

Canon

MARCH 2001

JY8-1319-000

COPYRIGHT © 2001 CANON INC.

***Printed in Japan
Imprimé au Japon***

Use of this manual should be strictly supervised
to avoid disclosure of confidential information.

Serial Number List

CanoScan D1230U	6683A001AA	AZQ000000-
	6683A003AA	DZQ000000-
	6683A004AA	EZQ000000-
	6683A005AA	FZQ000000-
	6683A006AA	LZQ000000-
	6683A007AA	JZQ000000-
CanoScan D1230UF	6684A002AA	CZR000000-
	6684A003AA	DZR000000-
	6684A004AA	EZR000000-
	6684A008AA	MZR000000-
	6684A009AA	KZR000000-
	6684A010AA	LZR000000-
FAU-S12	6687A001AA	AZS000000-
	6687A002AA	BZS000000-
CanoScan D2400U	6785A001AA	AZT000000-
	6685A002AA	DZT000000-
	6685A003AA	EZT000000-
CanoScan D2400UF	6685A001AA	AZU000000-
	6685A002AA	CZU000000-
	6685A003AA	DZU000000-
	6685A004AA	EZU000000-
	6685A005AA	FZU000000-
	6685A006AA	LZU000000-
	6685A007AA	JZU000000-
	6685A008AA	MZU000000-
FAU-S13	6774A001AA	AZV000000-
	6774A002AA	BZV000000-

CONTENTS

CHAPTER 1 : GENERAL DESCRIPTIONS

I. SPECIFICATIONS	1-1	III. SETTING UP THE SCANNER	1-7
II. PARTS CONFIGURATION	1-5	A. Precautions	1-7
A. Front View	1-5	B. Unlocking the Carriage Lock ...	1-8
B. Rear View	1-5	C. Connecting the Cables	1-9
C. FAU Front View	1-6	D. Scanning a Document	1-10
D. FAU Rear View	1-6	E. Connecting FAU	1-11
		IV. CUSTOMER'S DAILY	
		MAINTENANCE	1-14

CHAPTER 2 : OPERATION AND TIMING

I. BASIC OPERATION	2-1	III. IMAGE PROCESSING	2-13
A. Functions	2-1	A. Outline	2-13
B. Electrical System	2-2	B. Image Processing	2-13
C. Main PCB Input and Output ...	2-4	IV. CONTROL SYSTEM	2-20
D. Document Scanning		A. Control System Diagram	2-20
Sequence	2-6	B. Main PCB	2-20
II. OPTICAL SYSTEM	2-7	V. INTERFACE	2-21
A. Outline	2-7	A. Outline of USB Standard	2-21
B. Lamp Lighting Circuit	2-8	B. Benefits of USB Scanner	2-21
C. FARE (Film Automatic Retouch-		C. Signal Definitions	2-22
ing and Enhancement)	2-10	D. Interface Connection	2-22
D. Motor Control Circuit	2-12	VI. POWER SUPPLY	2-23

CHAPTER 3 : MECHANICAL SYSTEM

I. PARTS REPLACEMENT	3-1	III. PCBs	3-4
A. Precautions	3-1	A. Removing the Main PCB	3-4
II. EXTERNALS	3-2	B. Removing the Button PCB	3-6
A. Removing the Document		IV. OPTICAL SYSTEM	3-9
Cover	3-2	A. Removing the Scanning Unit ...	3-9
B. Removing the Top Cover and		B. Removing the Drive Motor	3-15
Document Glass	3-3	C. Attaching the Drive Motor	3-17

CHAPTER 4 : MAINTENANCE AND SERVICING

I. PERIODICAL REPLACEMENT PARTS	4-1	III. PERIODICAL SERVICING	4-1
II. CONSUMABLE PARTS DURABILITY	4-1	IV. SPECIAL TOOLS	4-1
		V. SOLVENTS AND LUBRICANTS	4-1

CHAPTER 5 : TROUBLESHOOTING

I. INTRODUCTION	5-1	C. Scanning Unit Movement Failure	5-5
A. Initial Check	5-1	D. Poor Image Quality	5-5
B. Others	5-1	E. Acoustic Noise	5-5
II. TROUBLESHOOTING FLOWCHART	5-2	IV. CANON SCANNER TEST	5-6
A. Power LED Failure	5-2	A. Outline	5-6
B. Communication Failure	5-3	B. Operating Environment	5-6
III. PROBLEM, CAUSE AND CORRECTIVE ACTION	5-4	C. Functions	5-7
A. Power LED Not Lighting	5-4	D. Functions Descriptions	5-8
B. Communication Failure	5-4	E. Error Message	5-16

CHAPTER 6 : PARTS CATALOG

FIGURE 001	6-2	FIGURE 200	6-6
FIGURE 100	6-4	FIGURE 300	6-8

APPENDIX

I. GENERAL CIRCUIT DIAGRAM (CanoScan D1230U)	A-1	III. MAIN PCB CIRCUIT DIAGRAM (CanoScan D1230U)	A-3
II. GENERAL CIRCUIT DIAGRAM (CanoScan D2400U)	A-2	IV. MAIN PCB CIRCUIT DIAGRAM (CanoScan D2400U)	A-10

CHAPTER 1

GENERAL DESCRIPTIONS

I. SPECIFICATIONS	1-1	III. SETTING UP THE SCANNER	1-7
II. PARTS CONFIGURATION	1-5	A. Precautions	1-7
A. Front View	1-5	B. Unlocking the Carriage Lock ...	1-8
B. Rear View	1-5	C. Connecting the Cables	1-9
C. FAU Front View	1-6	D. Scanning a Document	1-10
D. FAU Rear View	1-6	E. Connecting FAU	1-11
		IV. CUSTOMER'S DAILY	
		MAINTENANCE	1-14

Others

Operating environment	: Temperature : 10 to 35 degrees Relative humidity : 10 to 90%RH Air pressure : 613 to 1013 hPa
(When using FAU)	: Temperature : 10 to 35 degrees Relative humidity : 10 to 85%RH Air pressure : 613 to 1013 hPa
Power source	: 100V to 120V 220V to 240V
Power consumption	: 17W max. (during operation) 8W (during standby)
(When using FAU)	: 20W max. (during operation) 8W (during standby)
Dimensions (Scanner)	: 286.0 (Width) x 461.0 (Depth) x 92.5 (Height) mm
(FAU)	: 285.0 (Width) x 410.0 (Depth) x 31.0 (Height) mm
Weight (Scanner)	: 3.4kg
(FAU)	: 1.1kg

■ CanoScan D2400U

Scanner Main Unit

Type : Flatbed image scanner

Scanning Part

Image sensor : 10,680-pixel 6-line CCD
 Light source : Cold cathode fluorescent lamp
 Document type : Sheet, Book
 Document alignment position : Right-end corner
 Max. document size : A4/Letter size (216 x 297mm)
 Image output mode : Color 16-bit for RGB each
 Grayscale (256 gradations)
 Binary (black and white)
 Optical resolution : 2400 dpi x 4800 dpi
 Scanning time : 4.5ms/line (600 dpi or lower)
 9.0ms/line (601 dpi or higher)
 Cropping of scan area : One rectangular area only

FAU-S13 Scanning Part

Film type : Color and monochrome, negative and positive
 Film size : 35mm sleeve (preview : 3 frames, scan : 1 frame)
 35mm slide mount
 Brownie (Max. 120x60mm)
 4x5 inches
 Light source : Cold cathode fluorescent lamp
 Power source : Supplied from CanoScan D2400U
 Scanning time : 4.5 to 162.0ms/line (automatically selected depending on
 films)
 Cropping of scan area : One rectangular area only

Interface Part

Interface : USB connector (Universal Serial Bus 1.1)
 FAU connector (8-pin)
 Power connector (for AC adapter)

Operating Part

Start button : 1 each on D2400U and FAU-S13

Others

Operating environment	: Temperature : 10 to 35 degrees Relative humidity : 10 to 90%RH Air pressure : 613 to 1013 hPa
(When using FAU)	: Temperature : 10 to 35 degrees Relative humidity : 10 to 85%RH Air pressure : 613 to 1013 hPa
Power source	: 100V to 120V 220V to 240V
Power consumption	: 17W max. (during operation) 8W (during standby)
(When using FAU)	: 20W max. (during operation) 8W (during standby)
Dimensions (Scanner)	: 286.0 (Width) x 461.0 (Depth) x 92.5 (Height) mm
(FAU)	: 285.0 (Width) x 410.0 (Depth) x 31.0 (Height) mm
Weight (Scanner)	: 3.4kg
(FAU)	: 1.1kg

Specifications are subject to change without prior notice.

II. PARTS CONFIGURATION

A. Front View

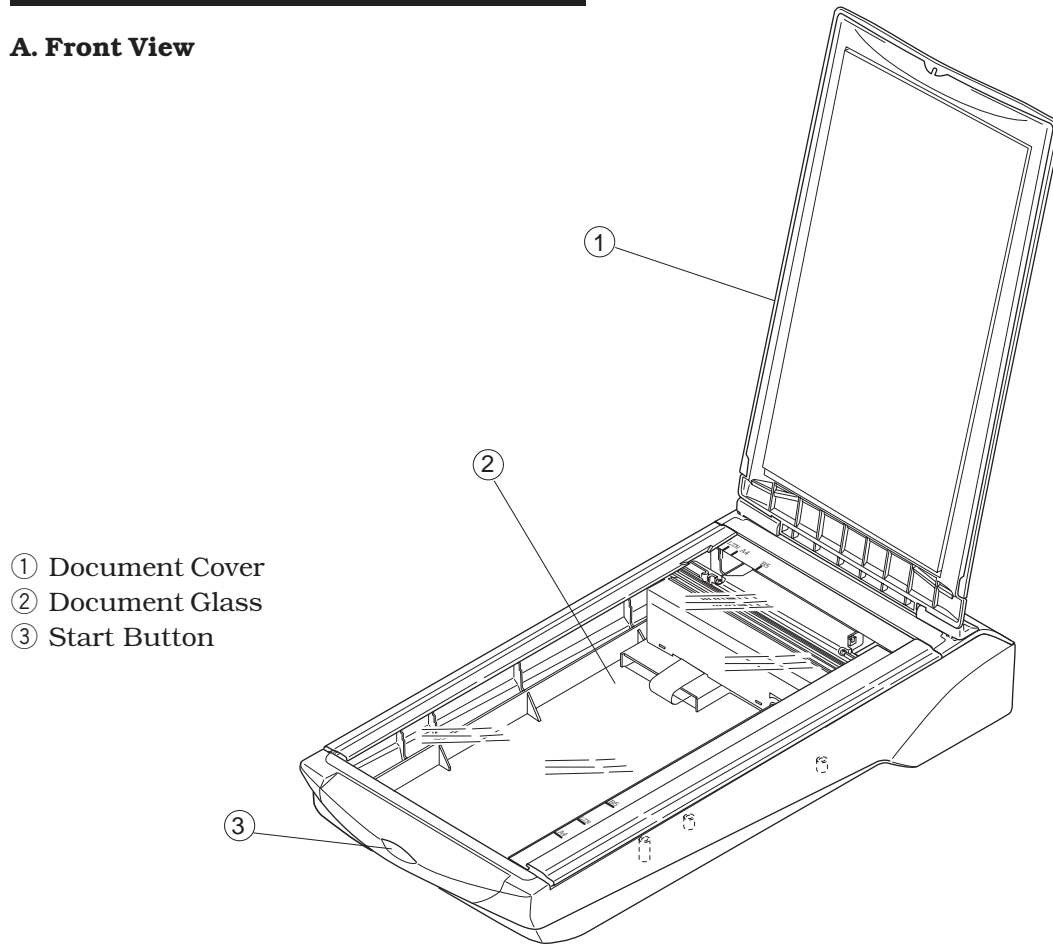

Figure 1-1

B. Rear View

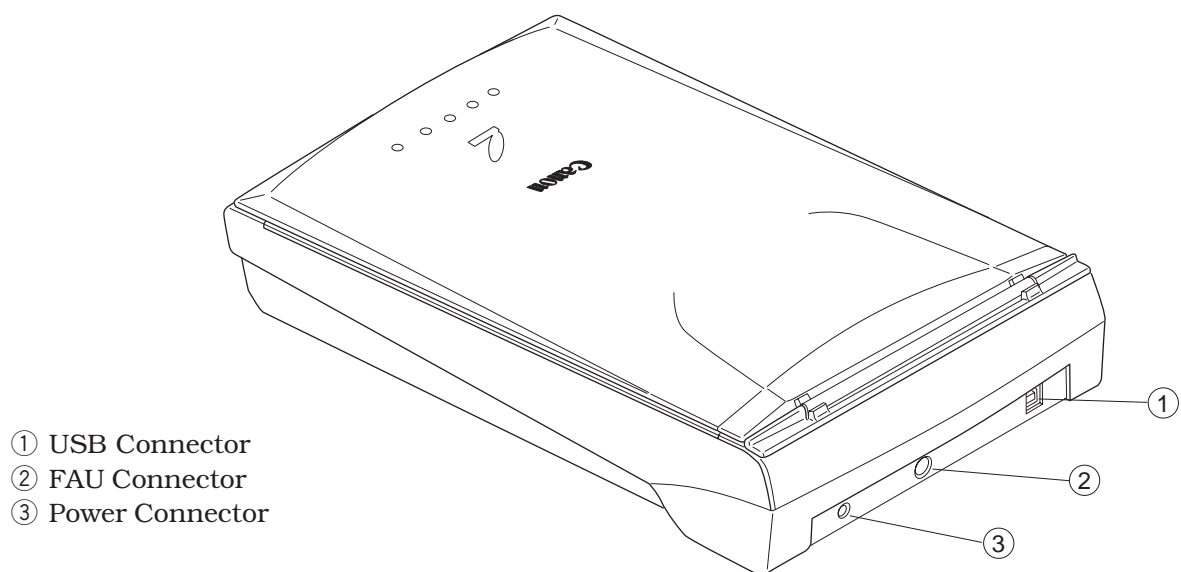
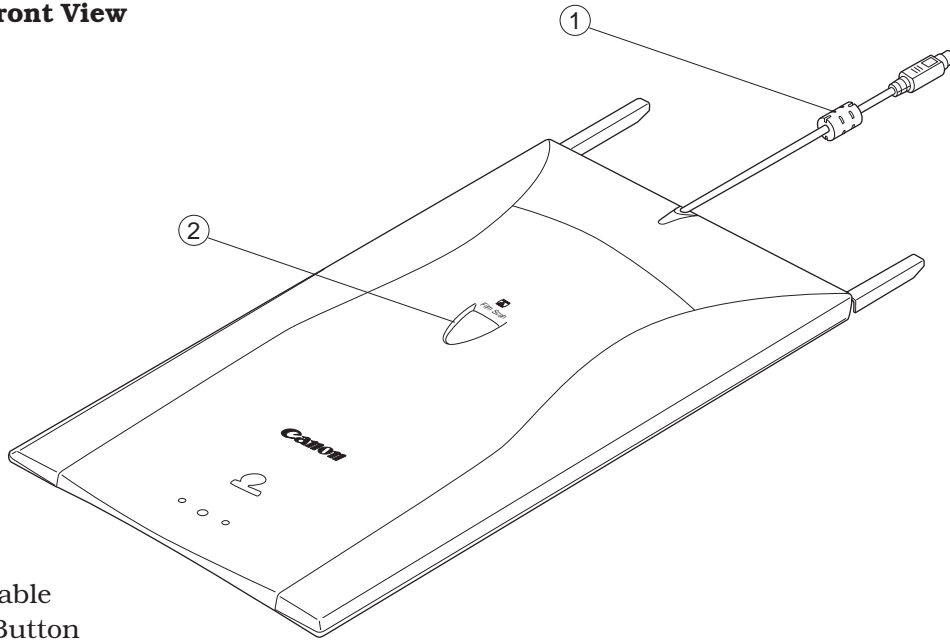

Figure 1-2

C. FAU Front View



- ① FAU Cable
- ② Start Button

Figure 1-3

D. FAU Rear View

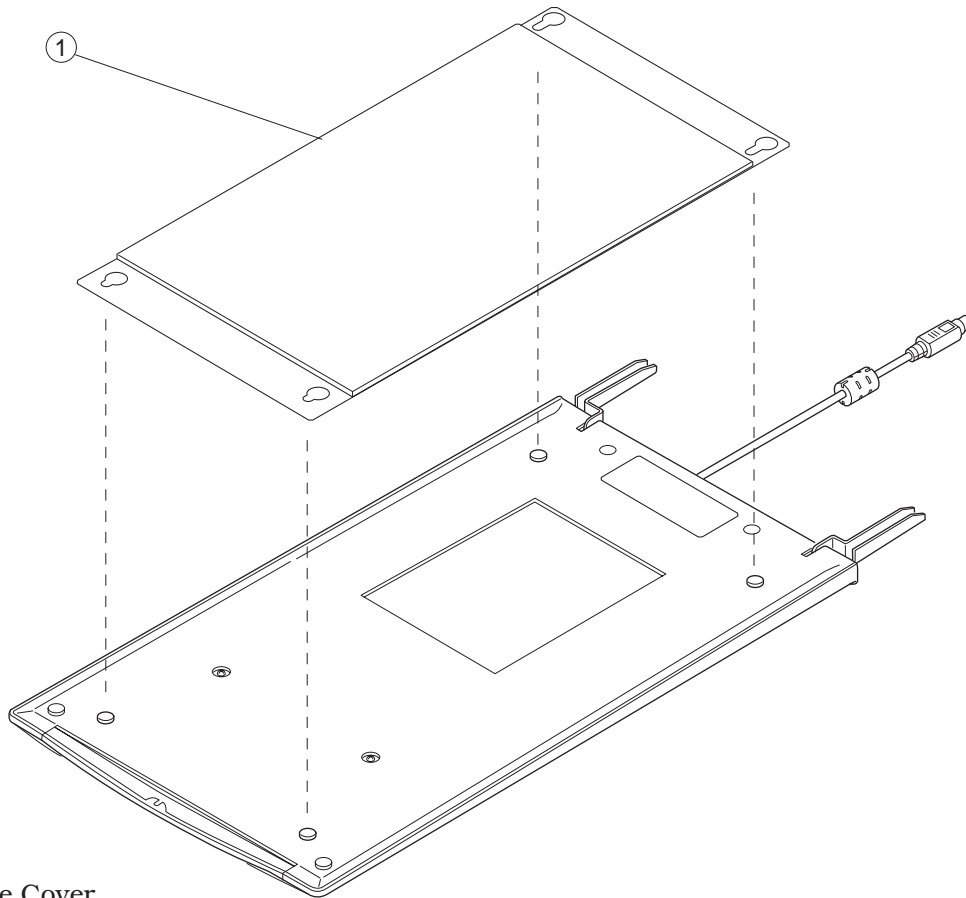

- ① Protective Cover

Figure 1-4

III. SETTING UP THE SCANNER

A. Precautions

- * Keep the scanner out of direct sunlight. Direct exposure to the sun or excessive heat may cause damage to the scanner.
- * Do not install the scanner in a humid or dusty environment.
- * Use the supplied AC adapter only.
- * Place the scanner securely on an even, flat surface. Tilted or uneven surface may cause a mechanical problem.
- * Keep the outer carton and packing material in case you may ship the scanner in the future.

B. Unlocking the Carriage Lock

Scanning unit is locked by the carriage lock to prevent a damage during transport. Unlock the carriage lock by pushing toward the “unlock” mark to use the scanner.

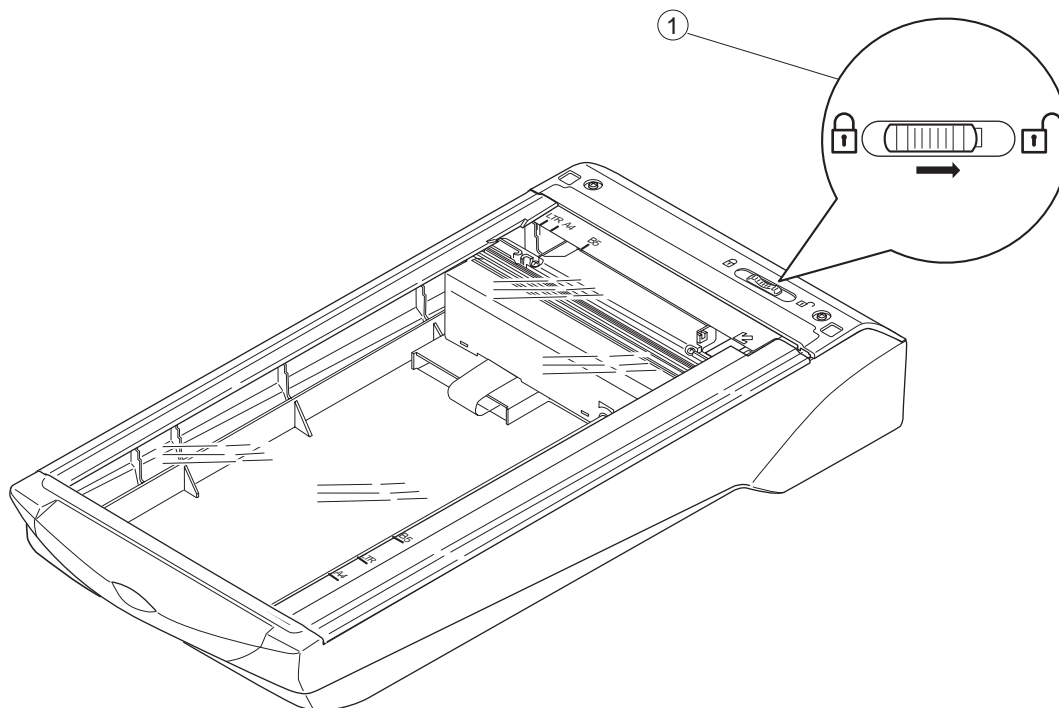

① Carriage Lock

Figure 1-5

Note : Ensure to lock the carriage lock during transport.

C. Connecting the Cables

D1230U/D2400U is connected to the USB port on the host computer. Refer to the "Getting Started" guide supplied with the product for details. For connecting the host computer's cables, refer to the manuals for the host computer.

1. Connecting the AC Adapter Cable and USB Cable

- 1) Connect the AC adapter cable to the power connector on the scanner.
- 2) Connect the square plug (B type) of the USB cable to the USB connector on the scanner, and connect the flat plug (A type) of the USB cable to the USB port on the host computer.

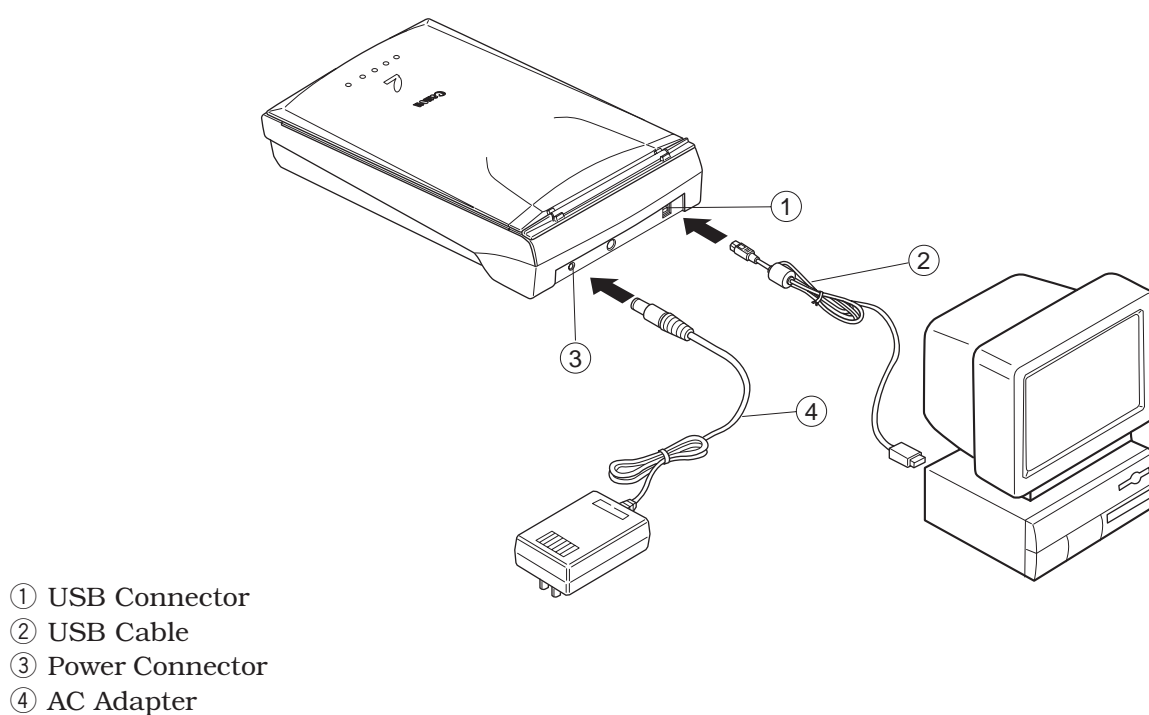
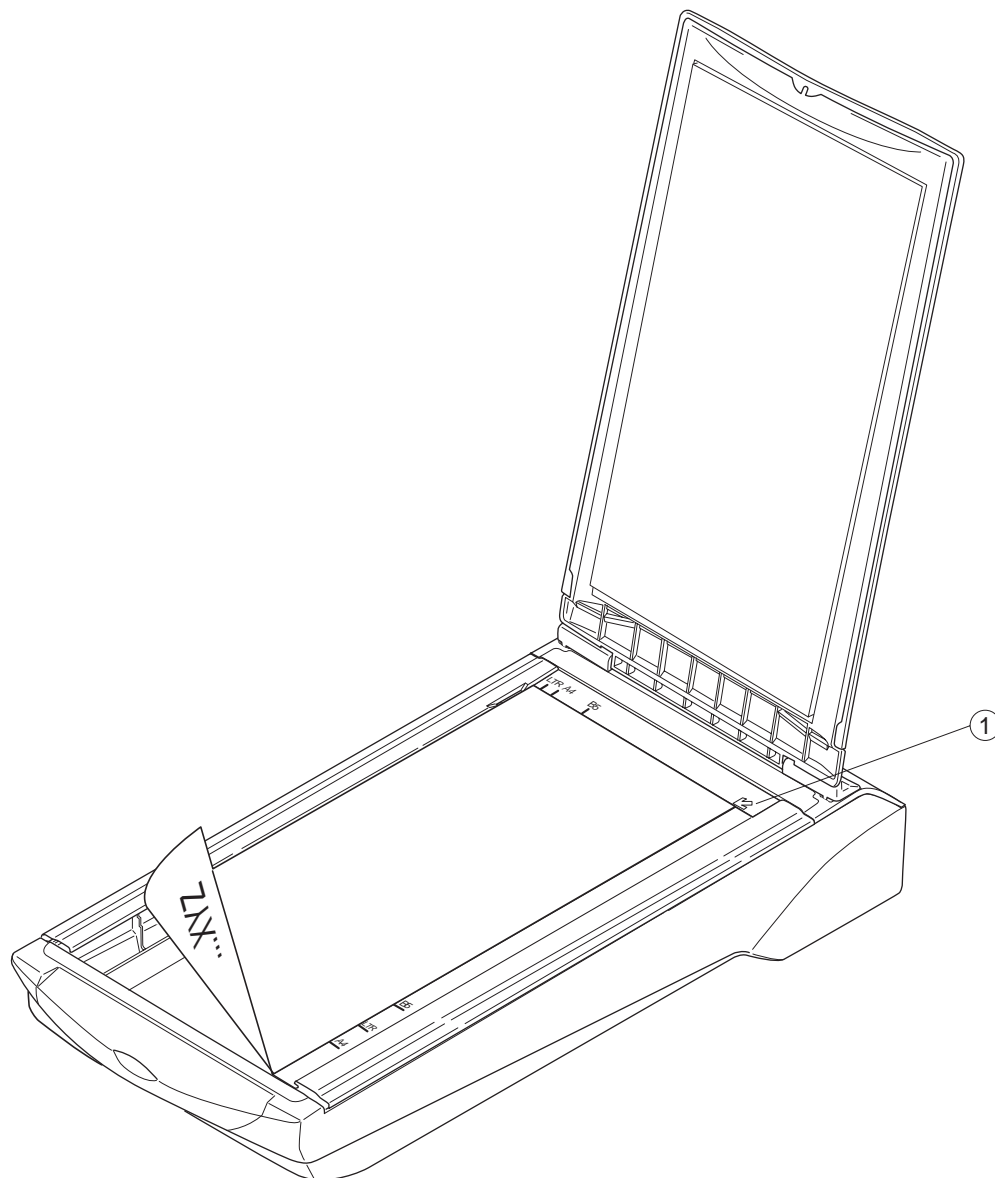

Figure 1-6

D. Scanning a Document

- 1) Open the document cover.
- 2) Place a document on the document glass, facing the image side down and aligning the upper corner with the alignment mark.



① Alignment Mark

Figure 1-7

- 3) Close the document cover, caring not to dislodge the document.
- 4) Send "SCAN" command from the host computer to scan.

E. Connecting FAU

FAU cable is connected to the FAU connector on the scanner. Refer to the “Getting Started” guide supplied with the product for details. For connecting the host computer’s cables, refer to the manuals for the host computer.

1. Setting Up FAU

- 1) Remove the document cover and unlock the carriage lock.
- 2) Attach FAU to the scanner.

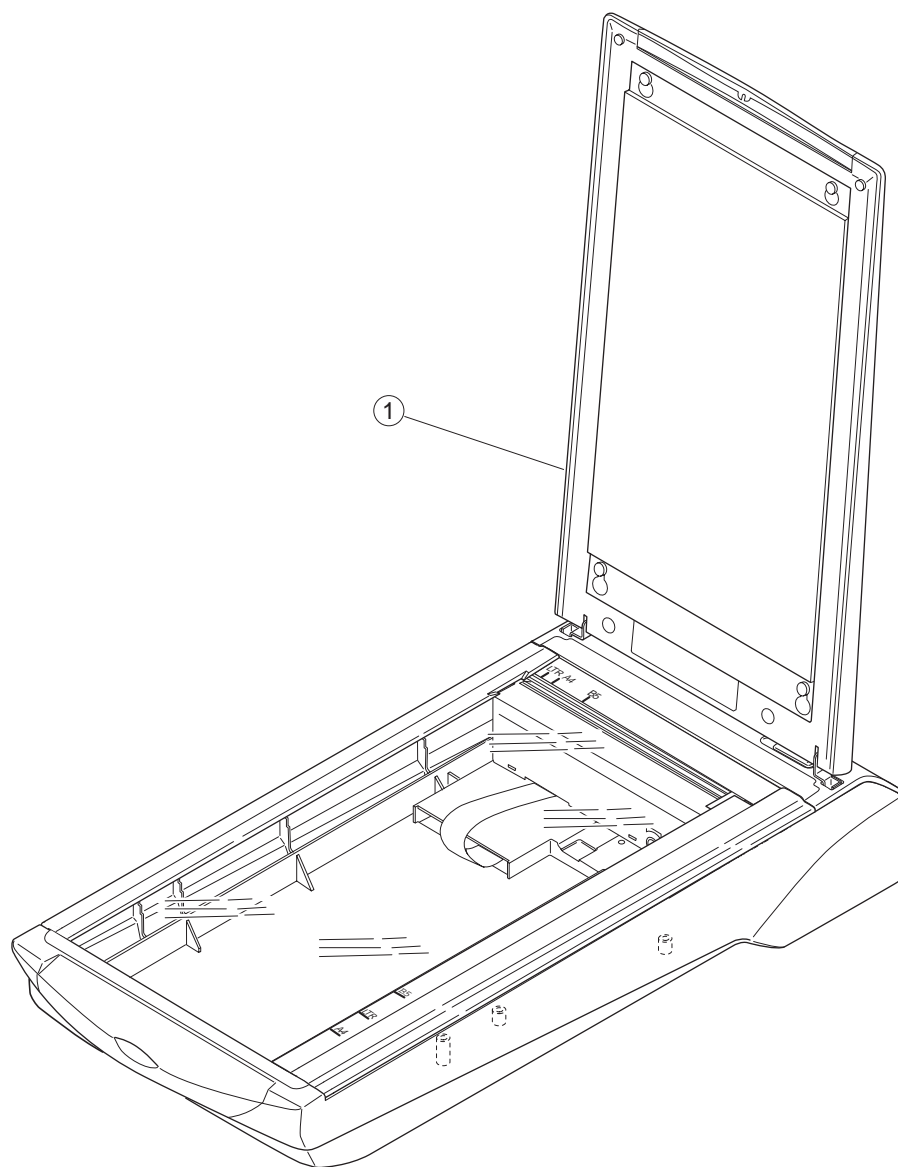

① FAU

Figure 1-8

2. Connecting FAU Cable to FAU Connector on the Scanner

- 1) Connect the AC adapter cable to the power connector on the scanner.
- 2) Connect the FAU cable to the FAU connector on the scanner.

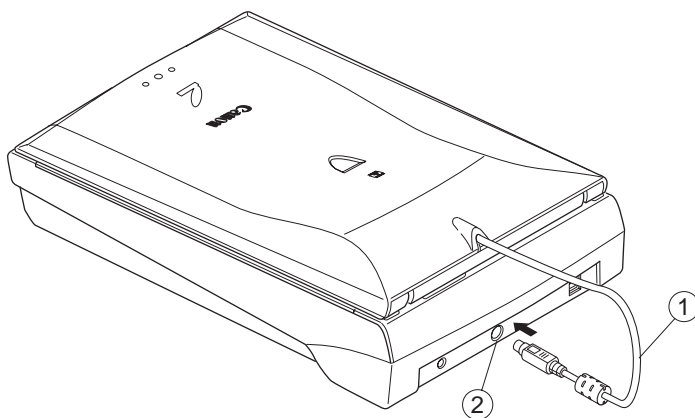

- ① FAU Cable
- ② FAU Connector

Figure 1-9

3) Remove the protective cover.

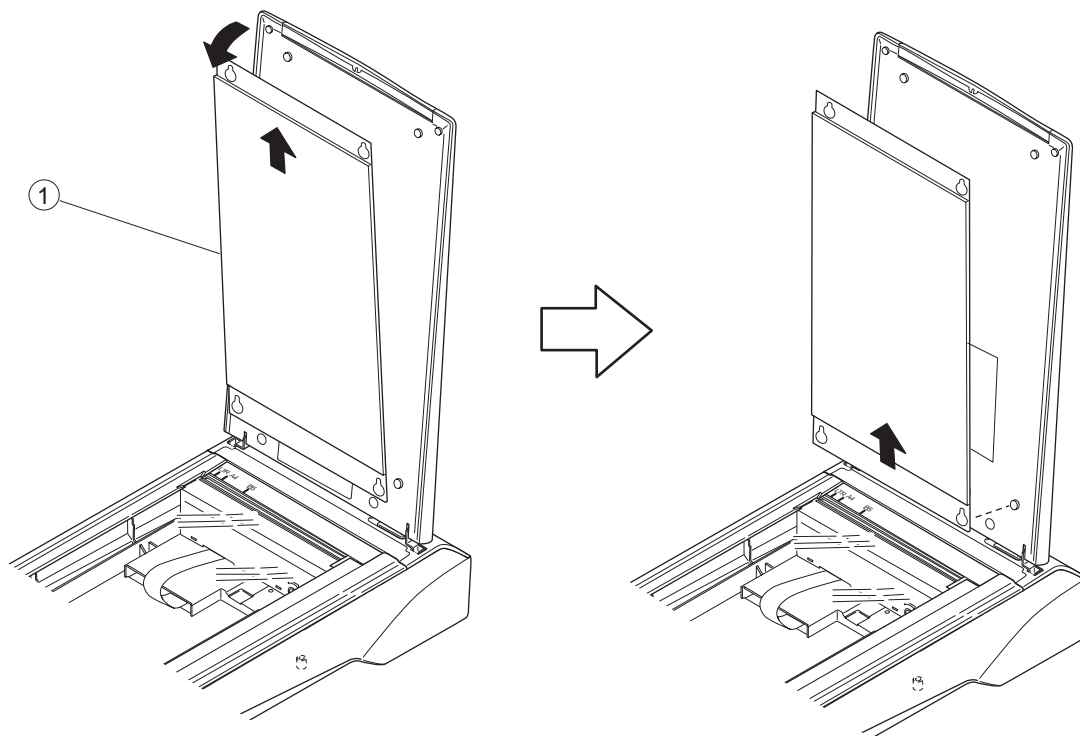

① Protective Cover

Figure 1-10

IV. CUSTOMER'S DAILY MAINTENANCE

Dirt on the document glass may cause an unclear image or lines on an image. Clean the document glass using the following steps.

- 1) Disconnect all cables from the scanner.
- 2) Wipe a dirt off the document glass with a soft clean cloth dampened with water and well wrung.
- 3) Thoroughly wipe water off the document glass with a dry cloth.

CHAPTER 2

OPERATION AND TIMING

I. BASIC OPERATION	2-1	III. IMAGE PROCESSING	2-13
A. Functions	2-1	A. Outline	2-13
B. Electrical System	2-2	B. Image Processing	2-13
C. Main PCB Input and Output ...	2-4	IV. CONTROL SYSTEM	2-20
D. Document Scanning		A. Control System Diagram	2-20
Sequence	2-6	B. Main PCB	2-20
II. OPTICAL SYSTEM	2-7	V. INTERFACE	2-21
A. Outline	2-7	A. Outline of USB Standard	2-21
B. Lamp Lighting Circuit	2-8	B. Benefits of USB Scanner	2-21
C. FARE (Film Automatic Retouching		C. Signal Definitions	2-22
and Enhancement)	2-10	D. Interface Connection	2-22
D. Motor Control Circuit	2-12	VI. POWER SUPPLY	2-23

I. BASIC OPERATION

A. Functions

The scanner functions are divided into optical system, image processing system, and control system.

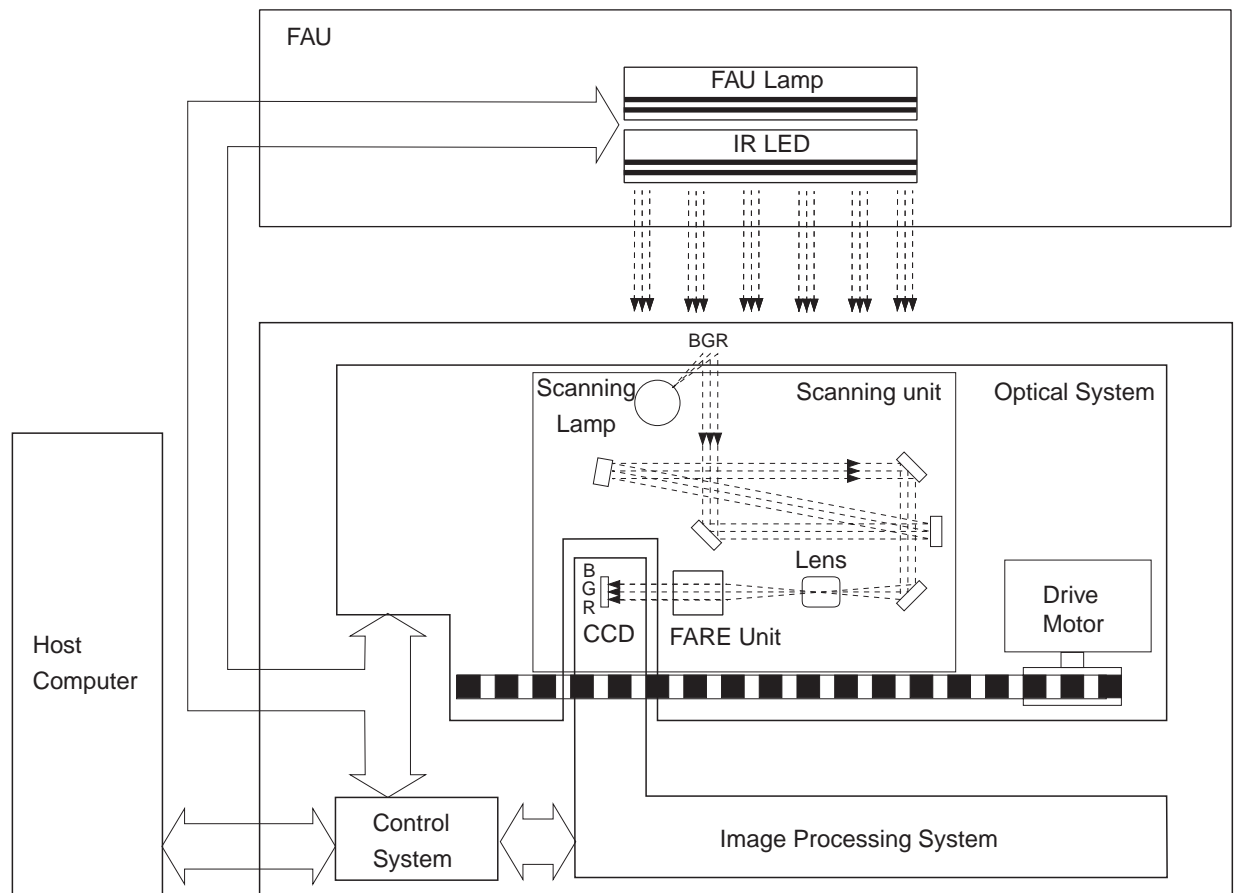

Figure 2-1

B. Electrical System

1. Outline

The scanner is not equipped with CPU. The device driver installed in the host computer includes a control program, which functions as CPU. Host computer sends a command to the ASIC via the USB controller, the ASIC controls the whole electrical circuits and image processing of the scanner. The image signals read by the CCD are converted into digital data by analog IC. The digital data is then processed by the ASIC and output to the host computer via USB interface.

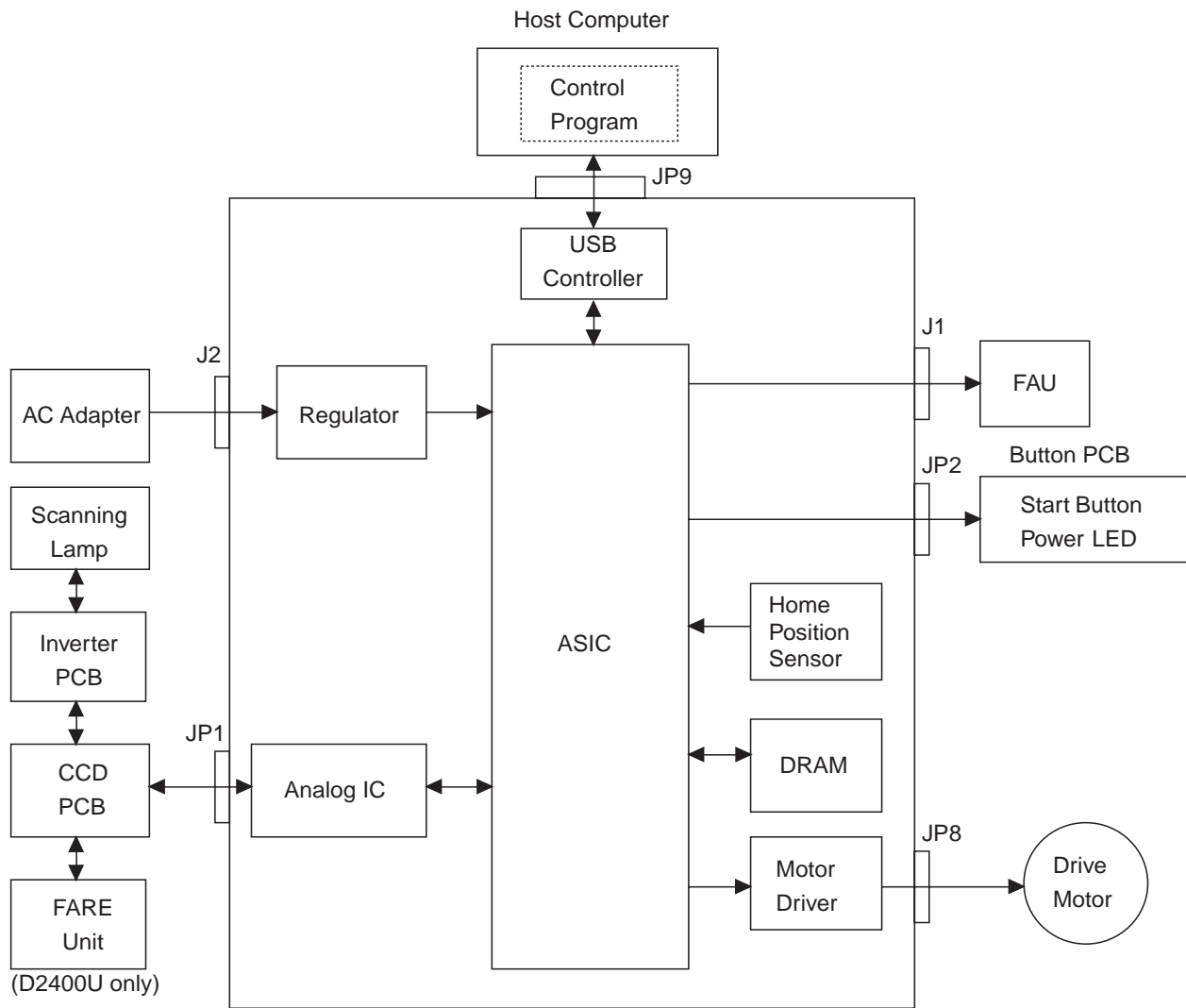

Figure 2-2

2. Functions of the Main PCB

1) Analog IC

Converts the image signals (analog signals) read by the CCD into digital data.

- CDS (Correlated Double Sampling)
- AGC (Auto Gain Control)
- 16-bit A/D converter (Analog-to-Digital Converter)

2) ASIC

Performs various processings:

- DRAM control
- CCD timing clock creation
- Line buffer control
- CCD output line difference adjustment
- Image processing (Binary processing, Image inversion)
- Shading correction
- Motor driver control

3) DRAM

Stores the shading correction data when performing shading correction, and the image data when scanning.

4) Motor Driver

Supplies power to the drive motor.

5) USB Controller

Controls data transfer between the host computer and ASIC.

C. Main PCB Input and Output

1. CanoScan D1230U

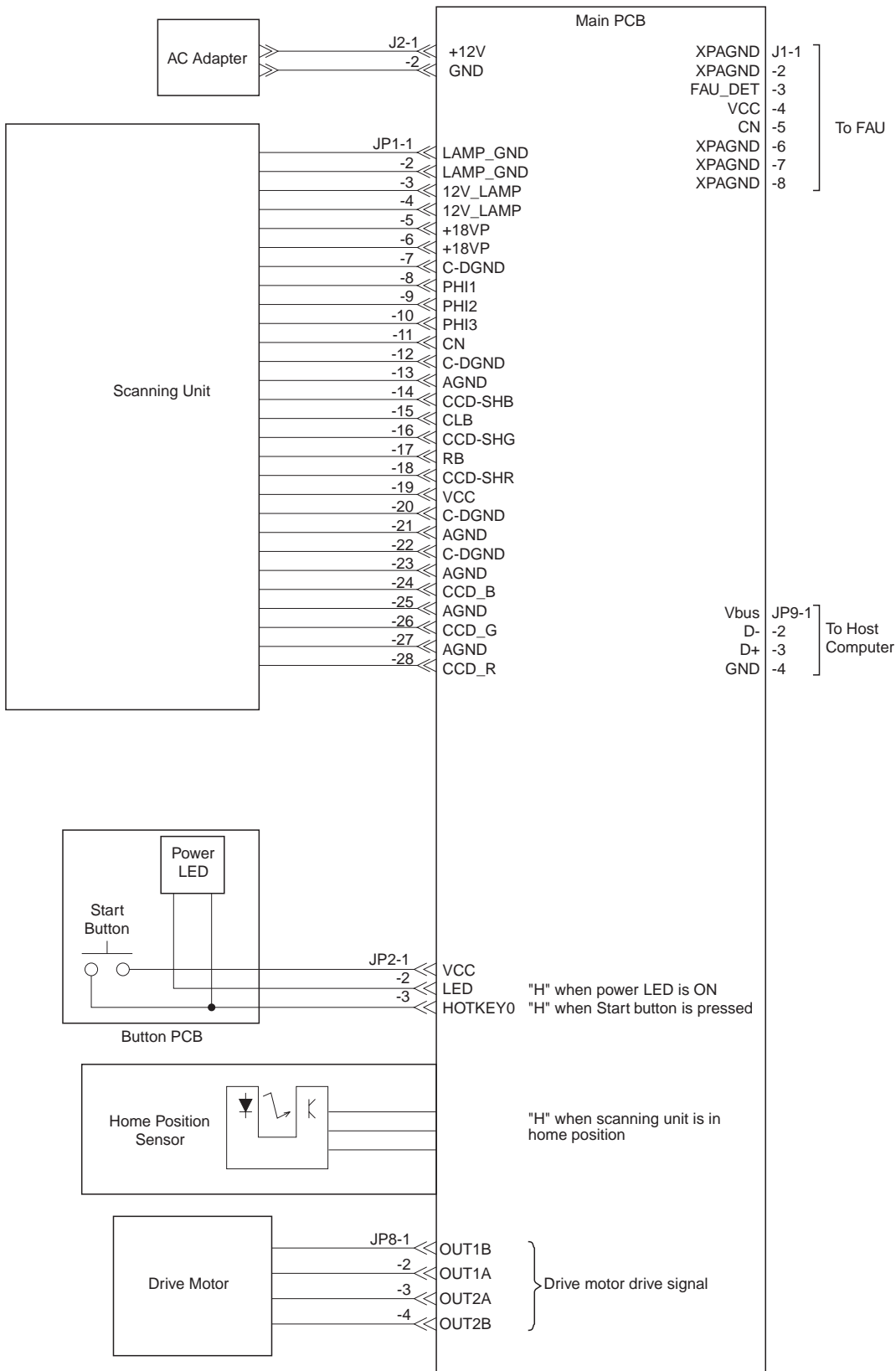

Figure 2-3

2. CanoScan D2400U

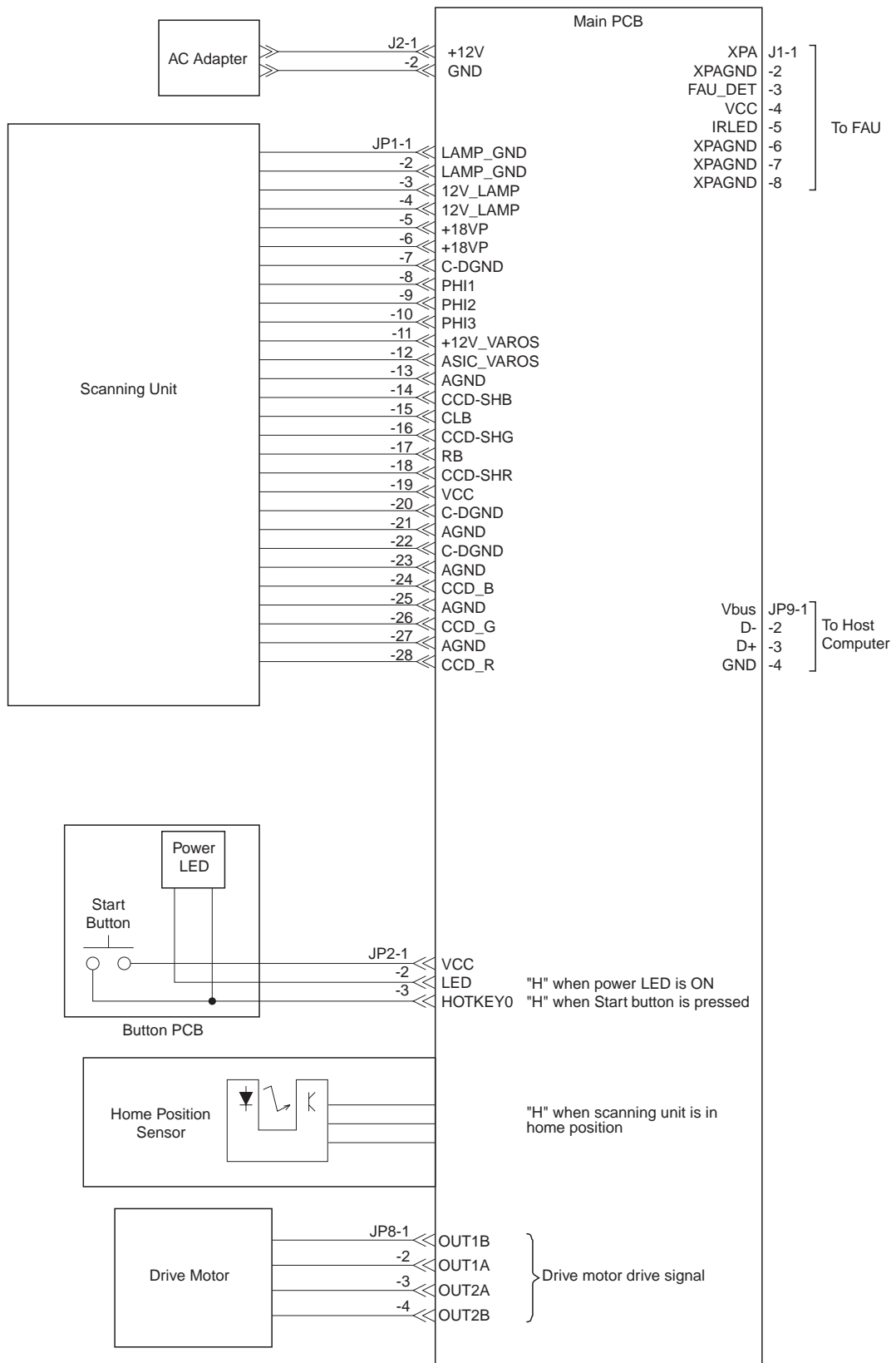

Figure 2-4

D. Document Scanning Sequence

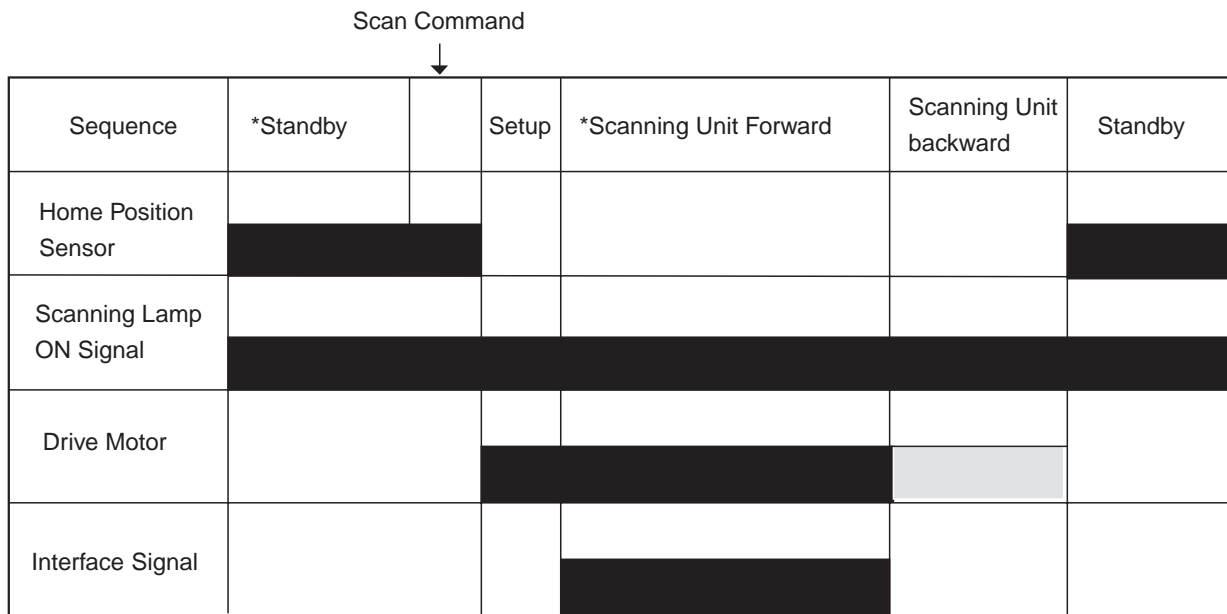

Figure 2-5

Sequence	Operation	Purpose	Remarks
Standby	After the scanner self test is completed until the scanner receives a scan command from the host computer	To maintain the scanner ready for scan	
Setup	From the scanner receives a scan command until it starts scanning	To execute calibration for setting light exposure time, gain data and shading data	The data is stored in DRAM
Scanning Unit Forward	After the scanner starts scanning until whole scan area specified by the host computer is scanned	To execute image processing according to the command from the host computer while scanning and send imada data to the host computer	
Scanning Unit backward	After the scanning unit starts moving backward until it returns to the home position	To return the scanning unit to the home position to ready for the next scan	Home position is detected by the home position sensor

Table 2-1

II. OPTICAL SYSTEM

A. Outline

The optical system consists of the scanning lamp, lens and mirrors. When scanning a reflective document, the scanning lamp in the scanning unit exposes the document and focuses the reflected light from the document on the light-sensitive device CCD (charge-coupled device) via the lens and mirrors.

When scanning a film, FAU lamp in the Film Adapter Unit transmits the film and focuses the transmitted light on the CCD.

When using FARE system, infrared LED transmits a film after FAU lamp does, and FARE unit operates to scan the film.

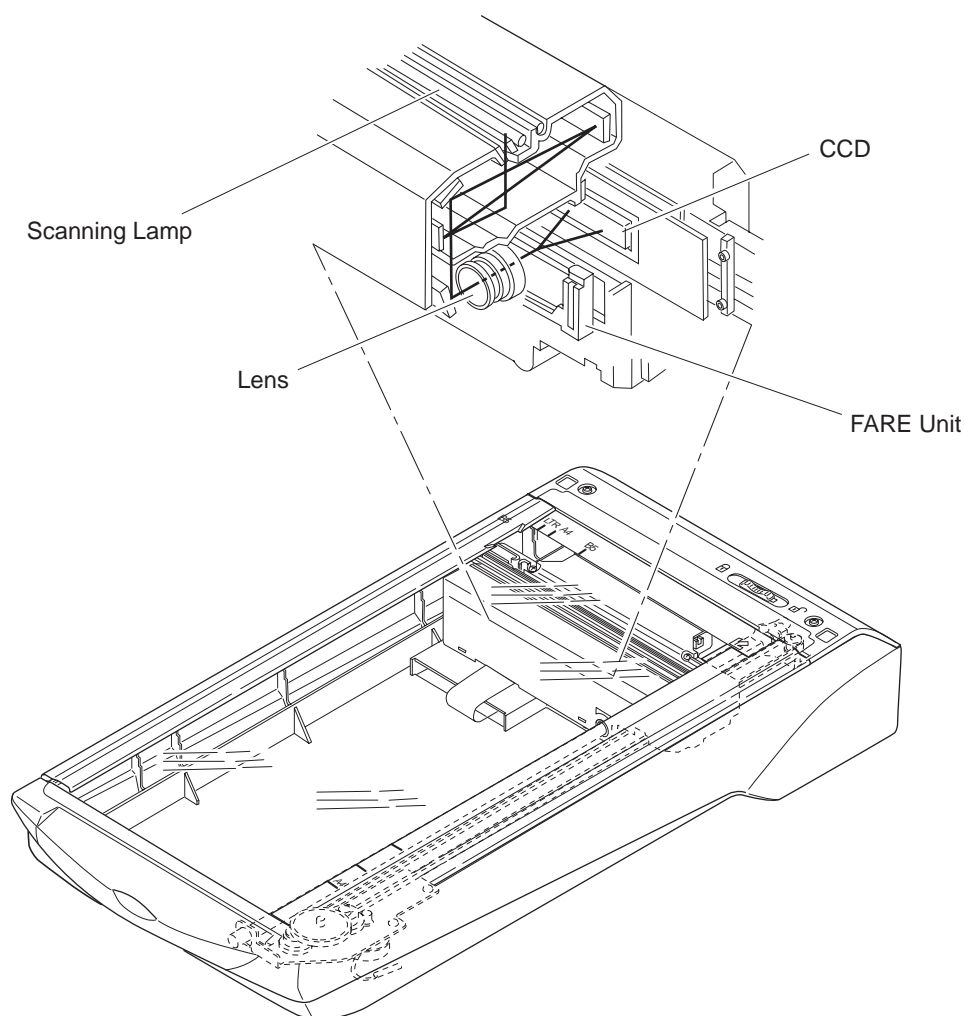

Figure 2-6

B. Lamp Lighting Circuit

1. Scanning Lamp Lighting Circuit

When the scanner is powered on, or the host computer sends a scan command, ASIC turns the scanning lamp lighting signal (LAMP) ON to light the scanning lamp.

The reflected light from the document is focused on the light-sensitive device CCD (charge-coupled device) via the five mirrors, lens and FARE unit.

The scanner is provided with a lamp OFF function for energy saving. A built-in timer to be set by the device driver is counted during lamp ON and turns the scanning lamp OFF when no scan command is sent for a certain period.

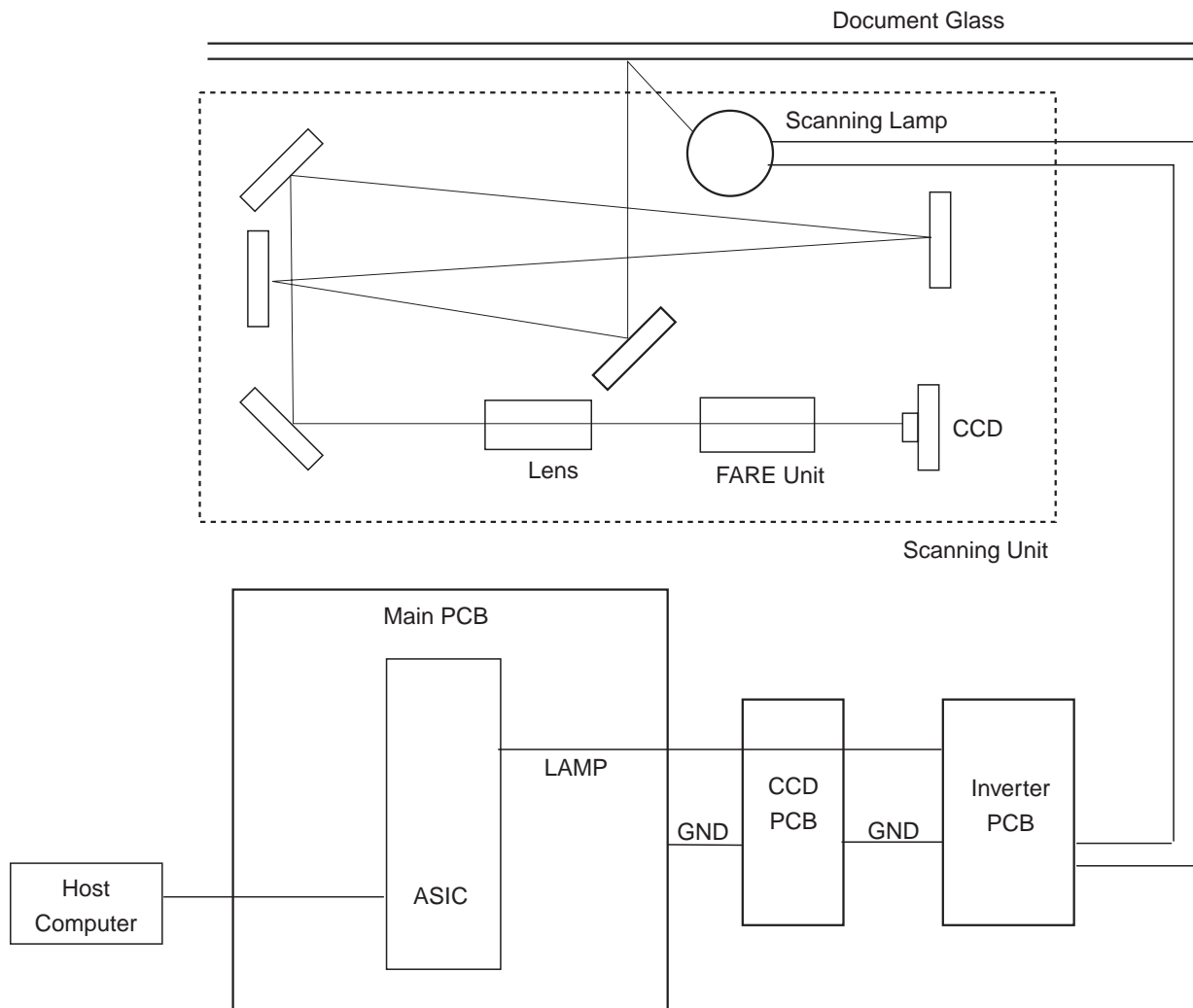

Figure 2-7

2. FAU Lamp Lighting Circuit

When the host computer sends a film scan command, ASIC turns the scanning lamp lighting signal (LAMP) OFF then turns FAU lamp lighting signal (XPA) ON to light the FAU lamp.

The FAU lamp light is converted into a flat light source by a light guide plate, then diffused via 1st diffusive film, brightness enhancement film and 2nd diffusive film. As a result, exposed light from a transparent plate has equal light intensity which transmits a film and focuses on the CCD in the scanning unit.

The FAU lamp also has a lamp OFF function for energy saving as in the case of the scanning lamp.

3. Infrared LED Lighting Circuit

When the host computer sends a command to light an infrared LED, ASIC turns IRLED signal ON to light the infrared LED.

The infrared LED light is converted into a flat light source by a light guide plate as in the case of the FAU lamp, which transmits a film via 1st diffusive film, brightness enhancement film, 2nd diffusive film and transparent plate.

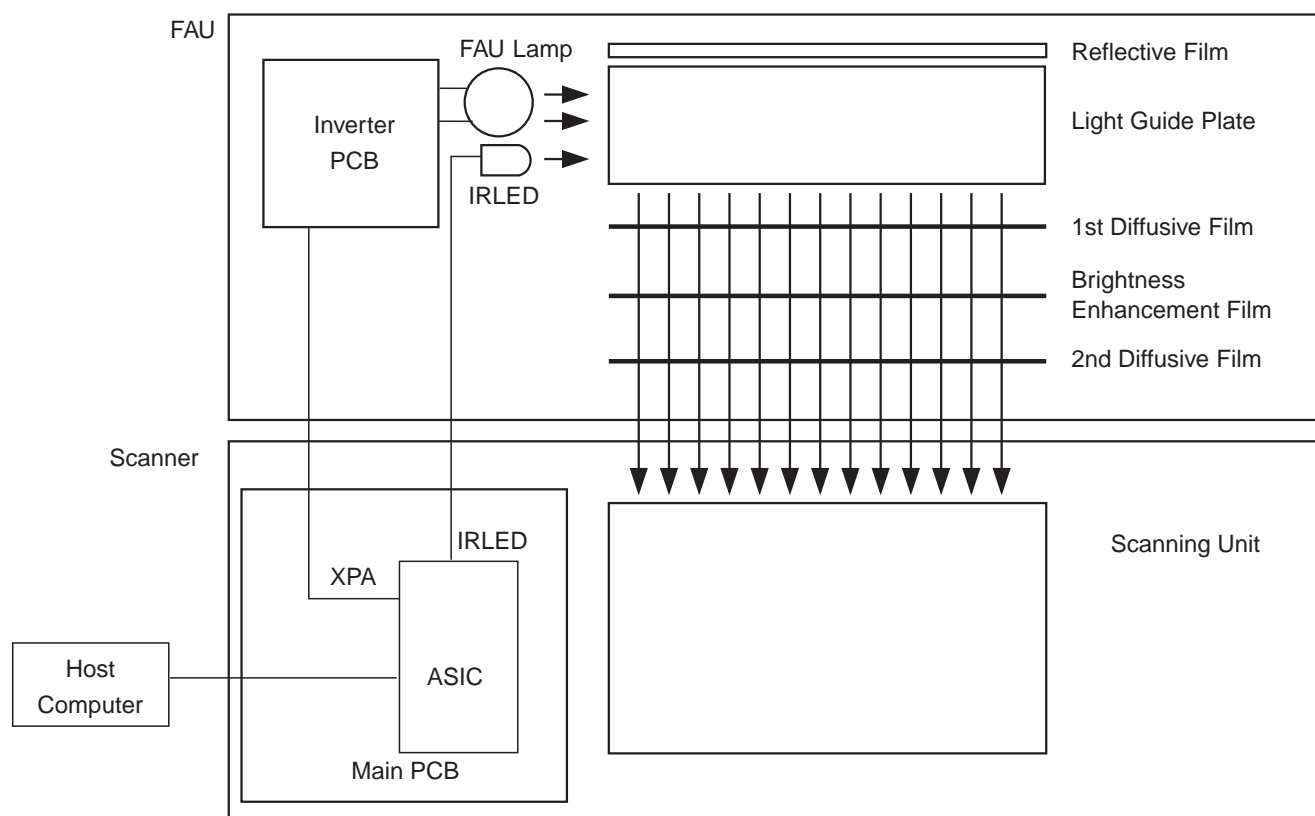

Figure 2-8

C. FARE (Film Automatic Retouching and Enhancement)

1. Outline

FAU-S13 attached to D2400U employs an infrared LED in addition to the FAU lamp (cold cathode fluorescent lamp) in order to remove scratches and dirt on a film by transmitting a film by two light sources. This system is called FARE (Film Automatic Retouching and Enhancement).

The infrared LED scans only scratches and dirt on a film as image data. This image data is compared to the full image data scanned by the FAU lamp, and the overlapping data of scratches and dirt is subtracted, then this area is compensated for by sampling the ambient data. Accordingly, the image without scratches and dirt is reproduced.

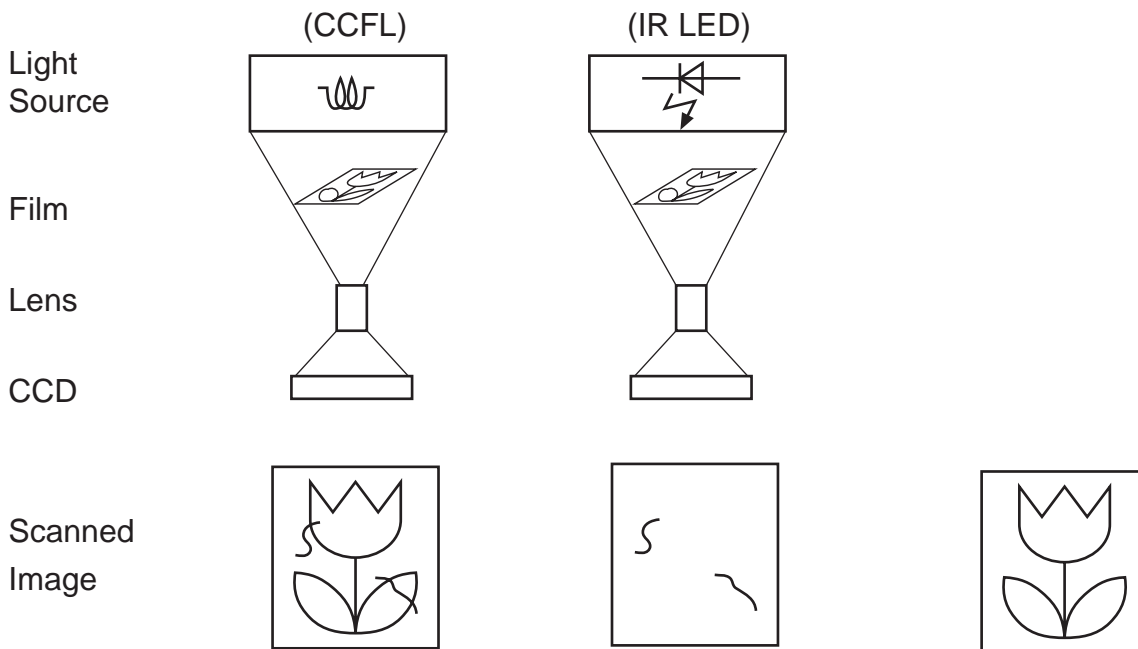

Figure 2-9

2. Operation of FARE system

The frequency of the FAU lamp (cold cathode fluorescent lamp) is 380-700nm, while that of the infrared LED is 880nm, therefore, their light refractive indexes differ resulting in out of focus (Figure 2-10-2).

As a solution, D2400U employs FARE unit between the CCD and lens, which consists of a refraction glass for changing the light refractive index and of an electromagnetic switch for changing the position of the refraction glass.

Firstly, the FAU lamp scans a film passing through the refraction glass. Secondly, the infrared LED scans a film, at the same time, the electromagnetic switch is turned ON to move the refraction glass to the position where the infrared LED light does not pass through (Figure 2-10-3).

Finally, the FAU lamp and infrared LED can scan a properly focused film.

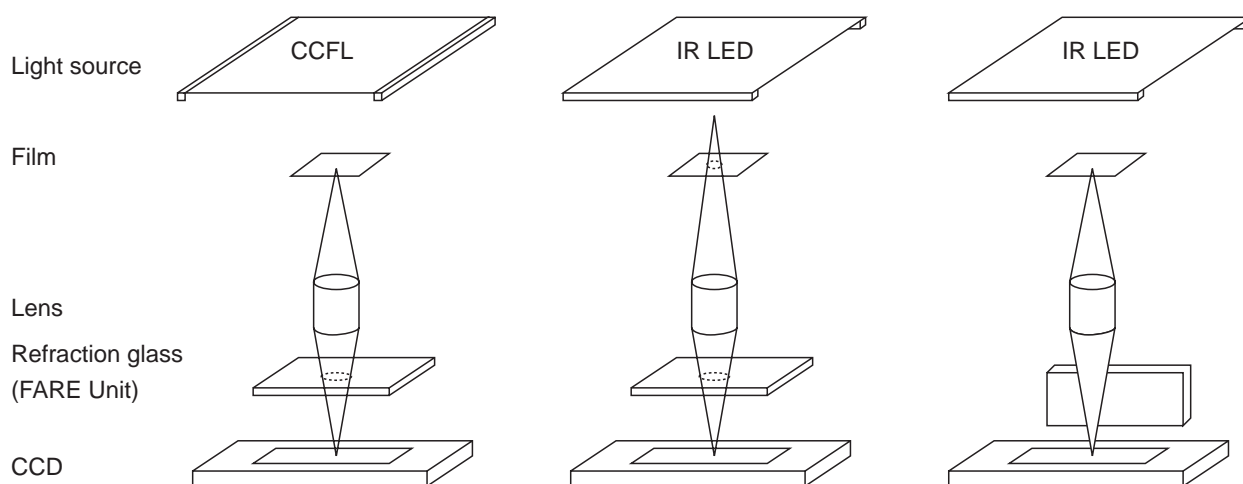

Figure 2-10-1

Figure 2-10-2

Figure 2-10-3

D. Motor Control Circuit

Control program analyzes a command sent from the host computer, and sends a motor clock generation command to ASIC. Gate array generates four-phase motor drive pulse signals [I01, I11, I02, I12], which are sent to the drive motor via motor driver.

When the host computer sends a command to change scaling/resolution, the control program commands the ASIC to change the frequency of the motor drive pulse signal to change the drive motor rotating speed.

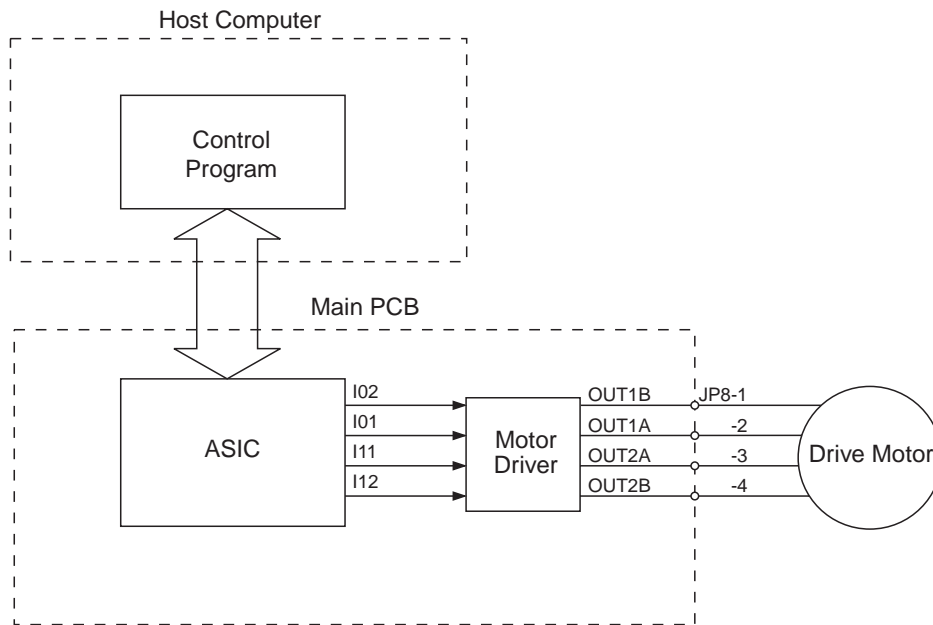

Figure 2-11

III. IMAGE PROCESSING

A. Outline

Image processing system consists of the CCD, analog IC, and ASIC. Analog signals read by the CCD is converted into digital data, then output to the host computer.

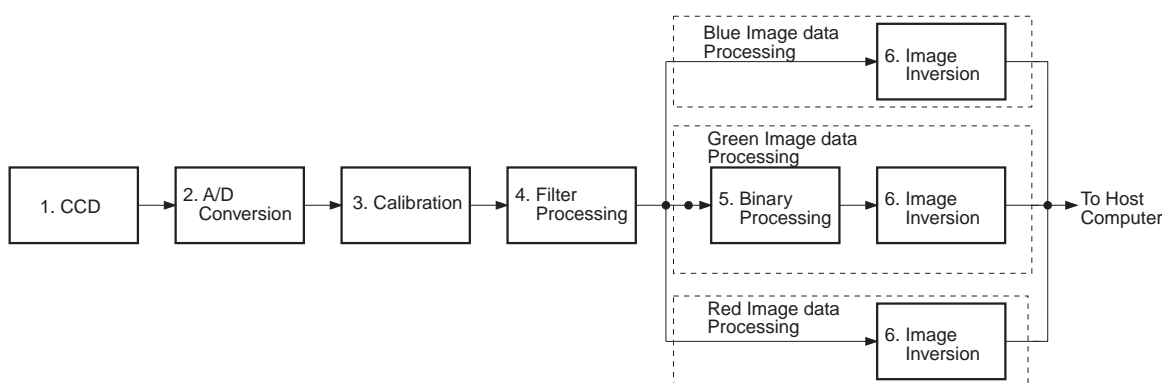

Figure 2-12

B. Image Processing

1. CCD

The CCD is a single chip photoelectric conversion device which consists of several thousand photosensitive devices of each several microns square, for reading RGB image signals, with a built-in scanning circuit.

D1230U employs 3-line CCD, and D2400U employs 6-line CCD.

1) 6-line CCD

6-line CCD has two rows of staggered photosensitive devices for RGB each. The 6-line CCD therefore can scan at $1200\text{dpi} \times 2 = 2400\text{dpi}$.

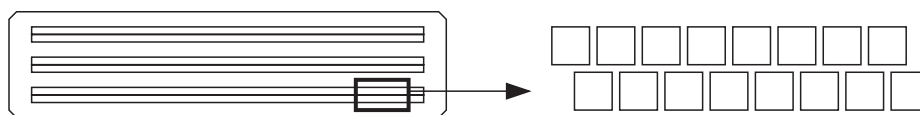

Figure 2-13

2. A/D Conversion

Output signal from the CCD is an analog signal which cannot be used as image data. So RGB output signal from the CCD is amplified by analog amplifier to generate analog data. The generated data is converted into averaged analog signal by D/A converter, then got feedback to the A/D converter to output constant digital data to the ASIC.

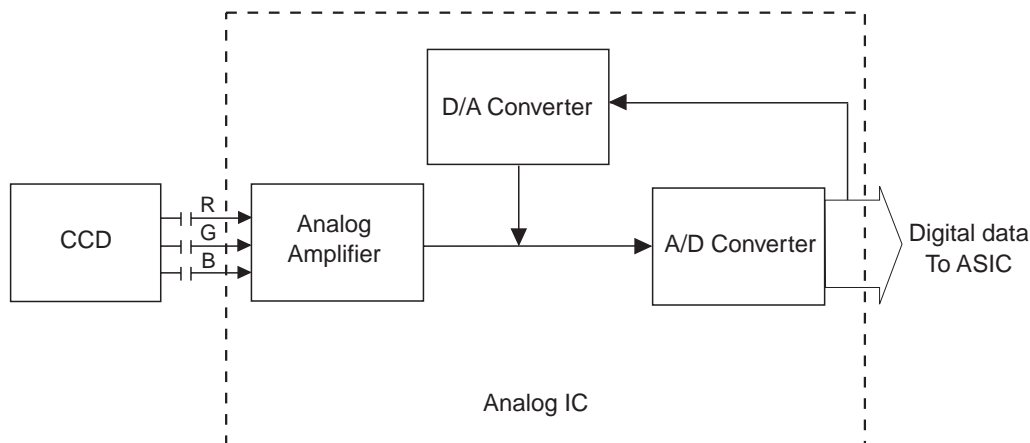

Figure 2-14

1) D/A Converter

D/A converter removes ununiform analog data generated by the CCD. It adjusts CCD output to keep max. 5V of input signal to the A/D converter, to make the black level of the image constant.

2) A/D Converter

The A/D converter converts the black-level-corrected image signal (analog signal) to a 16-bit image data (digital signal) in the order of red, green and blue image signal.

5V is applied to the Vcc terminal and reference voltage is applied to the Vref terminal. A/D converter outputs "0" when input signal is 5V, and outputs "65535" when input signal is reference voltage. This converts 1 pixel signal into the image data of 65536 gradations for red, green and blue each.

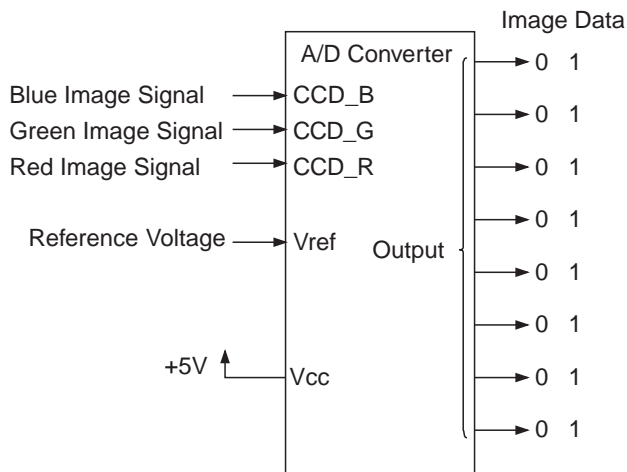

Figure 2-15

3. Calibration

Calibration can be performed to normalize the pixels of a linear CCD so that each pixel produces the same digital output code from the scanner when presented with the same image light intensity. This intensity ranges from black (no light) to white (maximum light intensity). The CCD's analog output may have large pixel-to-pixel variations in their output voltage when scanning the same white image (corresponding to errors on brighter signals). If these offsets are subtracted from each pixel, and each pixel is given the optimum gain setting to correct for different efficiencies, then these errors can be eliminated.

Ideally the digital output code for any pixel would be zero for a black image, and some code near the full scale for an image with maximum brightness. This code is called the target code.

The analog IC eliminates these global and pixel-to-pixel offset and gain errors with its Correlated Double Sampling, Offset D/A converter, Variable Gain Amplifier (VGA), and Programmable Gain Amplifier (PGA).

Calibrating an analog IC-based system requires three steps:

1) Offset Calibration

Takes a black image and normalizes the digital output code for each pixel at or near 0.

2) Boot-Gain/Coarse-Gain Stage Calibration

Finds the optimum gain setting that places the output voltage from all pixels from x0.93 to x9 adjustment range of these two stages.

3) Shading Correction from ASIC

Calculates the gain required for normalizing the output from each pixel to the target code.

4. Filter Processing

When converting resolution and scaling, the image quality tends to be reduced. To prevent the image quality reduction, filter processing is performed according to the resolution. Filter processing includes interpolation processing and averaging.

1) Interpolation Processing

When reading images at higher resolution, the one pixel output of the CCD is treated as two image data in the horizontal scanning direction, and the one line output of the CCD is treated as two image data in the vertical scanning direction, causing a reduced image quality. To prevent the image quality reduction, interpolation processing is performed. Figure 2-16 shows a change in image density by the interpolation processing.

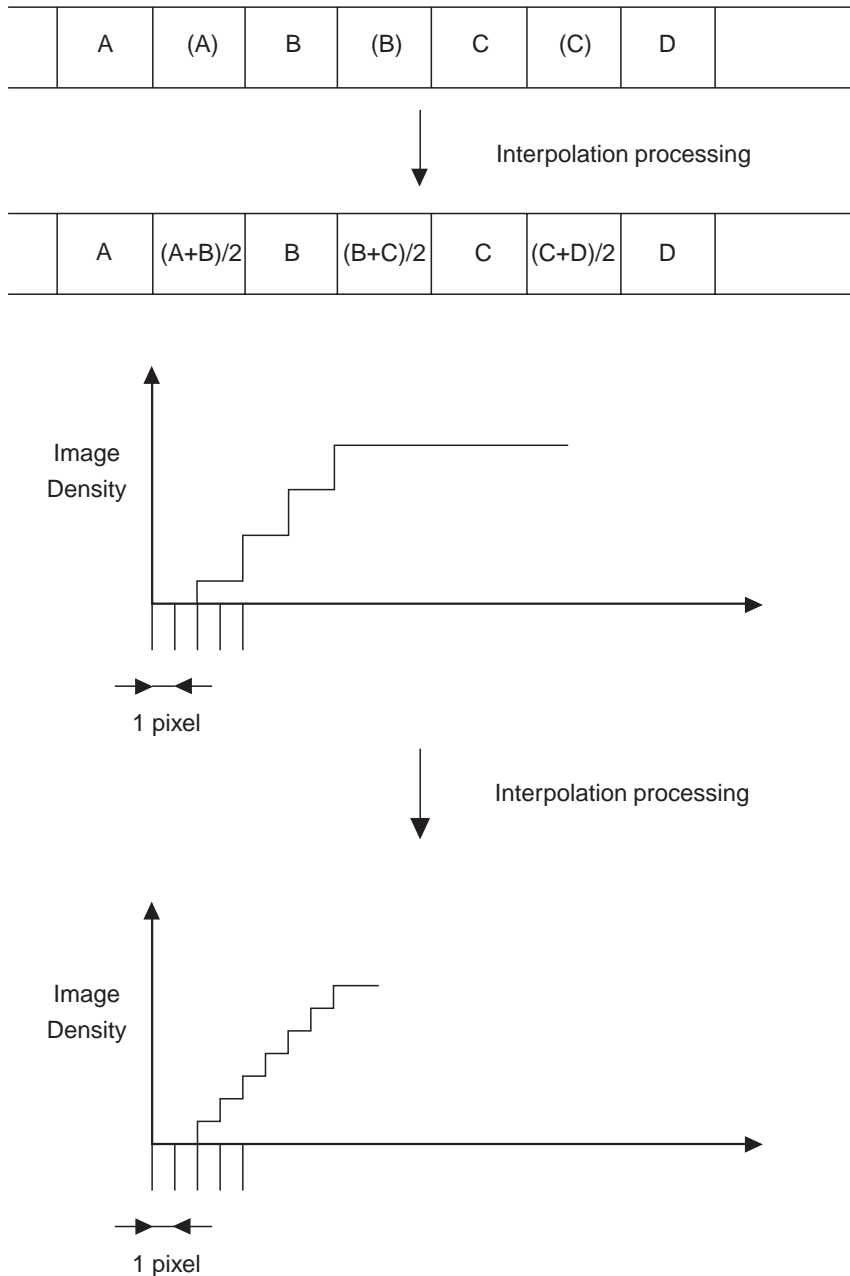

Figure 2-16

2) Averaging

When reading images at lower resolution, the thinned data increases resulting in output image deterioration. Averaging is a process in which the data to be thinned and the data to be actually output are averaged and output, in order to suppress the image deterioration due to the data thinning.

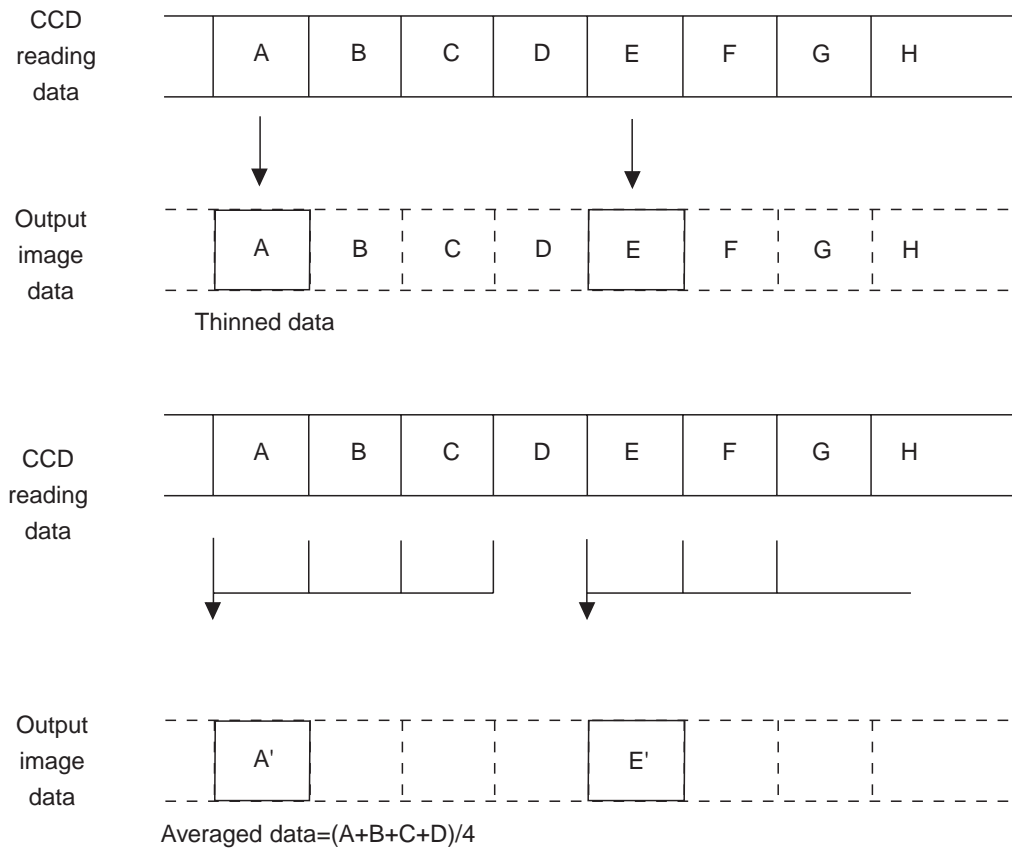

Figure 2-17

5. Binary Processing

Binary processing converts the 8-bit grayscale data into binary data in which 1 bit indicates white or black.

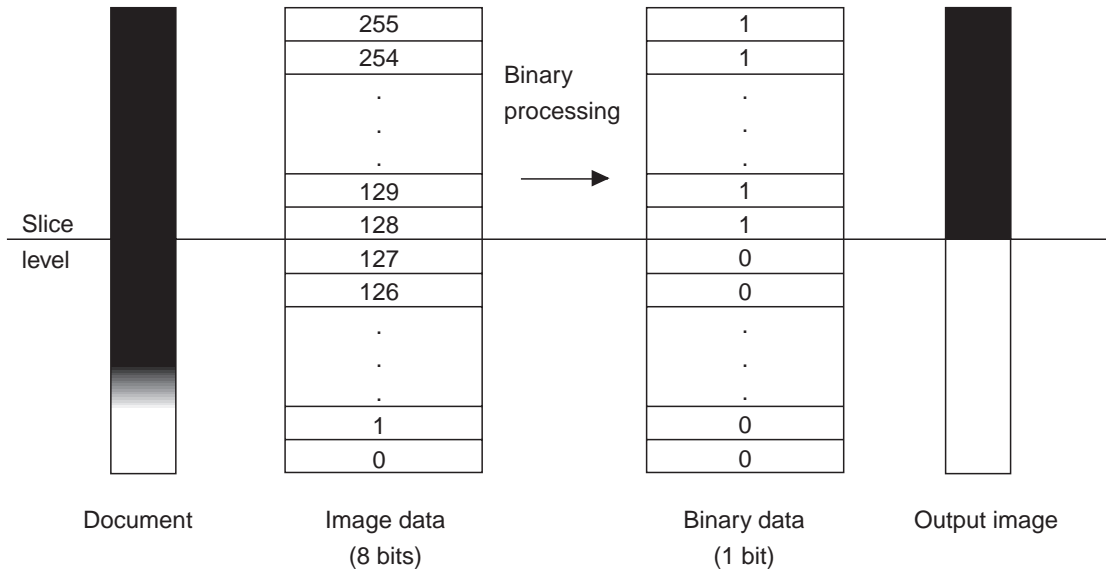

Figure 2-18

The ASIC sets parameters (slice level) in the slice level register when the host computer commands binary processing. The comparator compares the image data with the slice level, and converts the data into binary data consisting of 1 (black) or 0 (white).

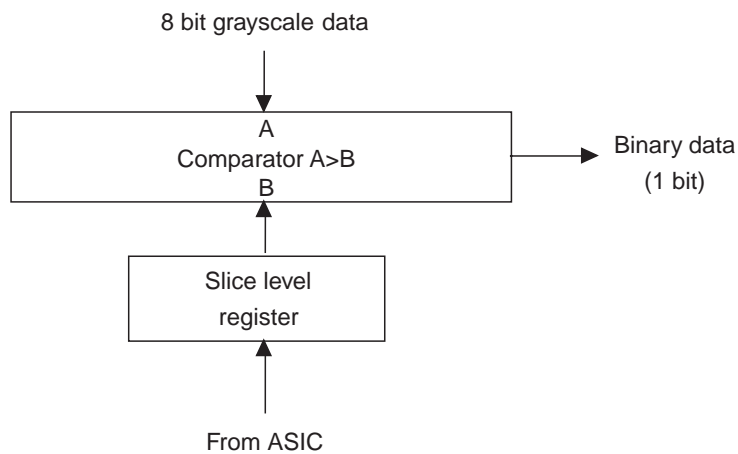

Figure 2-19

6. Image Inversion (negative/positive)

Image inversion is to reverse the density level of a document by inverting the color data, 8-bit grayscale data or binary data.

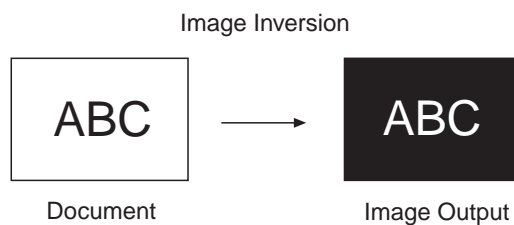

Figure 2-20

IV. CONTROL SYSTEM

A. Control System Diagram

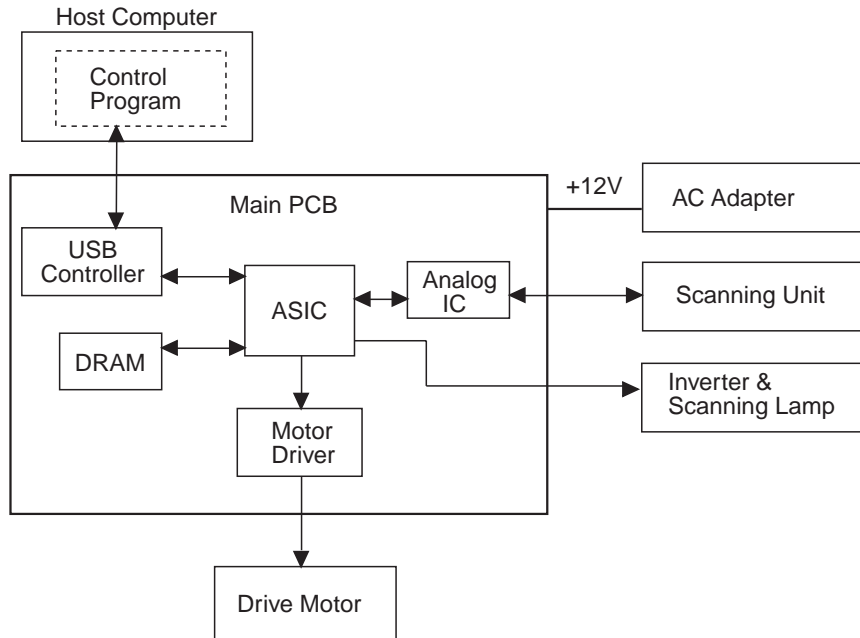

Figure 2-21

B. Main PCB

The scanner is not equipped with CPU. The device driver installed in the host computer includes a control program, which functions as CPU. Control program sends a command to the ASIC in the main PCB, the ASIC controls the whole electrical circuits and image processing of the scanner.

Main PCB consists of ASIC, DRAM, USB controller, analog I/C and motor driver.

V. INTERFACE

A. Outline of USB Standard

Since early 1997, the Universal Serial Bus (USB) has been the standard on most PCs. The USB standard was developed by Compaq, IBM, Intel, Microsoft, NEC, and Northern Telecom. It resulted from an industry-wide initiative to standardize peripheral attachments to PCs, and to improve the speed, performance and ease of use of PC peripherals.

B. Benefits of USB Scanner

1. True Plug & Play

Unlike the previous generation of SCSI scanners, no add-in cards are required to setup the USB scanners. This eliminates complex procedures, such as opening the box to install a card, or reconfiguring the system (setting DMA, IRQ, jumper cables, etc.) The USB scanners are simply plugged in and unplugged at any time.

2. Higher Speed

USB scanner is nearly 10 times faster than a standard parallel-port scanner at bandwidth 12 Mbits/sec. for data transfer.

3. Multiple Devices Support

USB specification can support up to 127 devices simultaneously on a computer by using "hub" terminals as additional plug-in ports.

C. Signal Definitions

USB uses two differential signal lines (D+ and D-) only to communicate with the host computer.

Pin	Signal	
1	VBUS	
2	D-	
3	D+	
4	Signal GND	
Shell	Chassis GND	

Table 2-2

D. Interface Connection

USB connector has A plug for connecting to upper layer and B plug for connecting to lower layer.

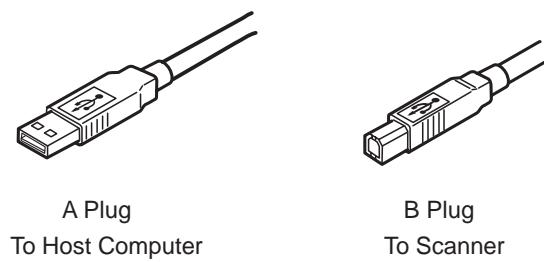

Figure 2-22

VI. POWER SUPPLY

DC power is supplied from the supplied AC adapter. Through power regulator, four DC power sources (+3.3V, +5V, +12V and +15V) are used in the circuit. +3.3V and +5V are supplied for the digital circuit and linear chip, +15V is for the CCD PCB, and +12V is for the motor driver and scanning lamp.

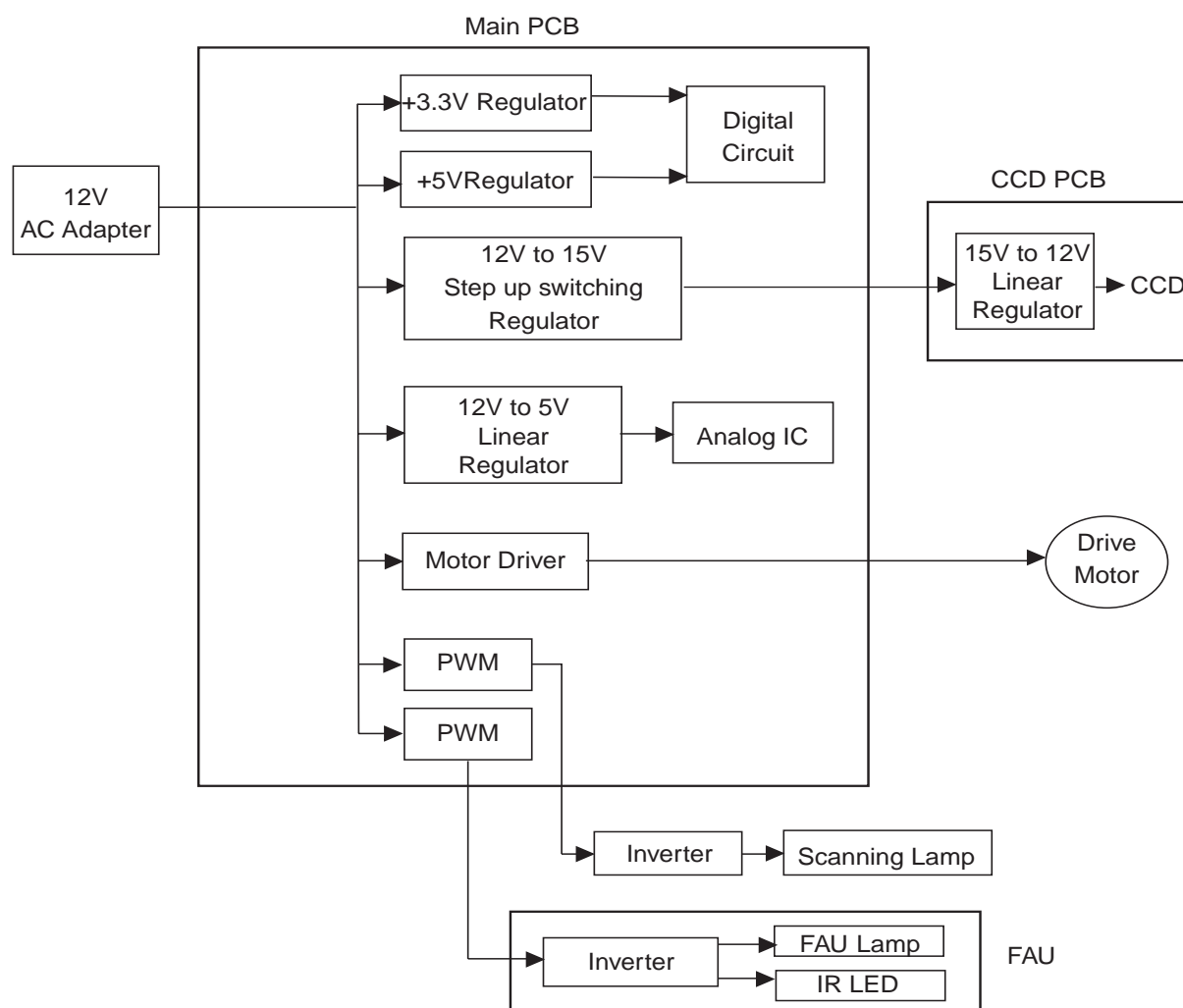

Figure 2-23

CHAPTER 3

MECHANICAL SYSTEM

I. PARTS REPLACEMENT	3-1	III. PCBs	3-4
A. Precautions	3-1	A. Removing the Main PCB	3-4
II. EXTERNALS	3-2	B. Removing the Button PCB	3-6
A. Removing the Document		IV. OPTICAL SYSTEM	3-9
Cover	3-2	A. Removing the Scanning Unit ...	3-9
B. Removing the Top Cover and		B. Removing the Drive Motor	3-15
Document Glass	3-3	C. Attaching the Drive Motor	3-17

I. PARTS REPLACEMENT

A. Precautions

- * Disconnect the AC adapter, USB cable, and FAU cable from the scanner before replacing the parts.
- * Wear anti-static gloves and grounding strap around the wrist during the work.
- * Follow the instructed steps. Do not remove any screw from the parts that is not to be replaced.
- * Store the removed parts in a clean place and avoid missing.
- * Attach the parts in reverse order of the removing steps, unless otherwise specified.
- * After replacement, check the quantity and shape of the replaced parts.

II. EXTERNALS

A. Removing the Document Cover

1) Open the document cover until it is perpendicular to the main frame, then lift to remove it.

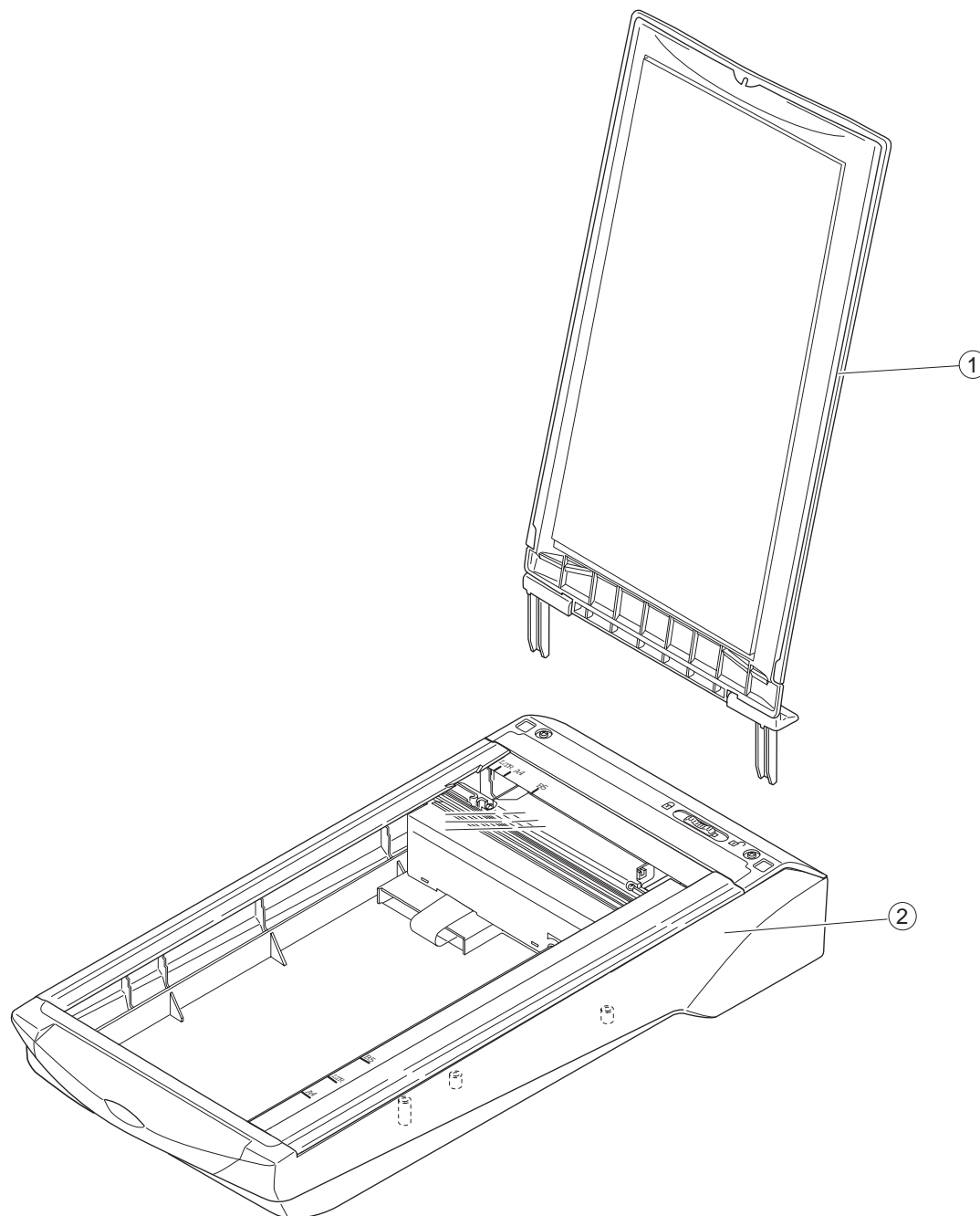

- ① Document Cover
- ② Main Frame

Figure 3-1

B. Removing the Top Cover and Document Glass

- 1) Remove two screws from the top cover, then lift the top cover and document glass to remove them.

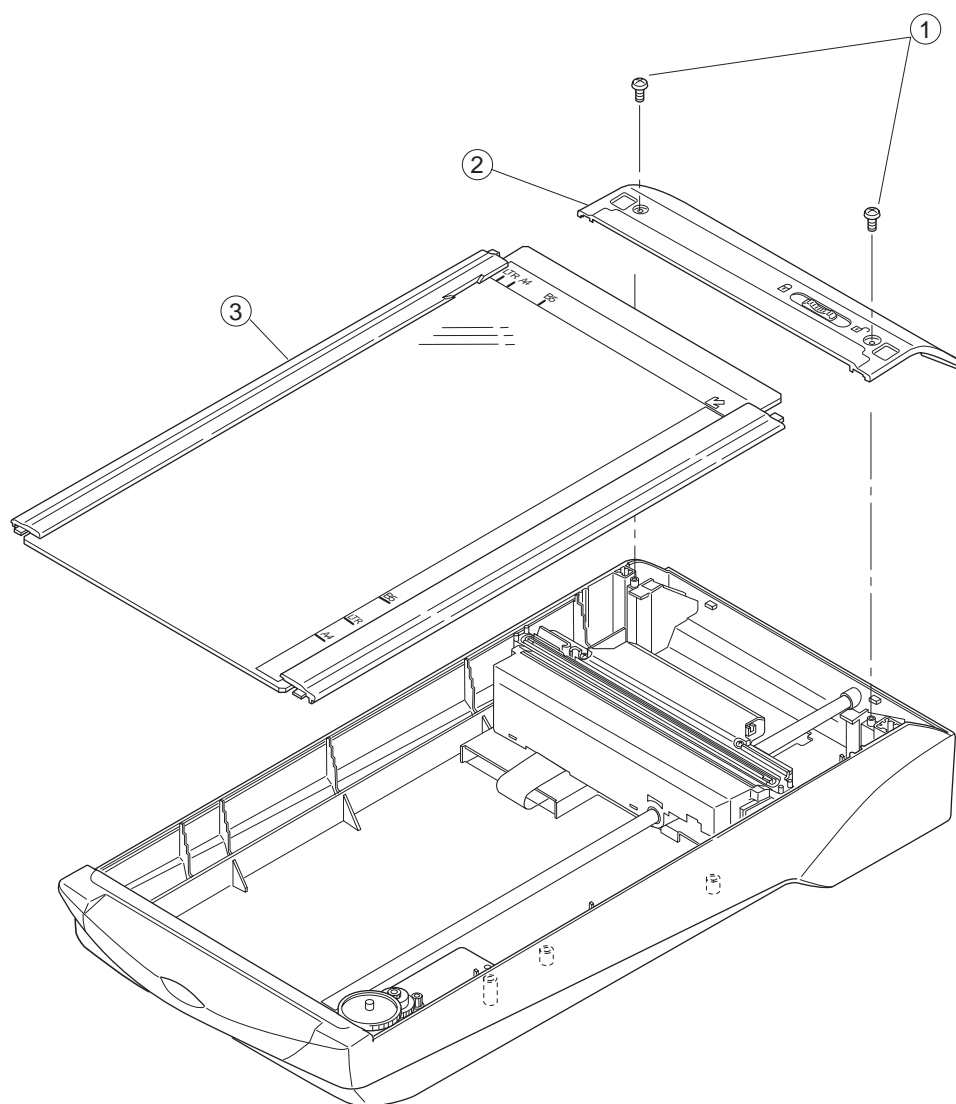

- ① Screw
- ② Top Cover
- ③ Document Glass

Figure 3-2

III. PCBs

A. Removing the Main PCB

1) Remove three screws from the bottom of the scanner to take out the main PCB.

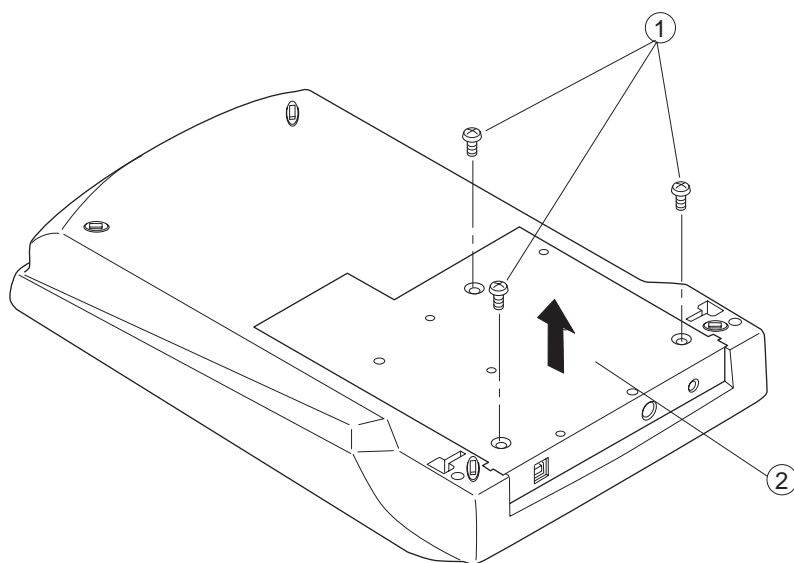

- ① Screw
- ② Main PCB

Figure 3-3

- 2) Disconnect the cables for the drive motor, button PCB and scanning unit from the main PCB.

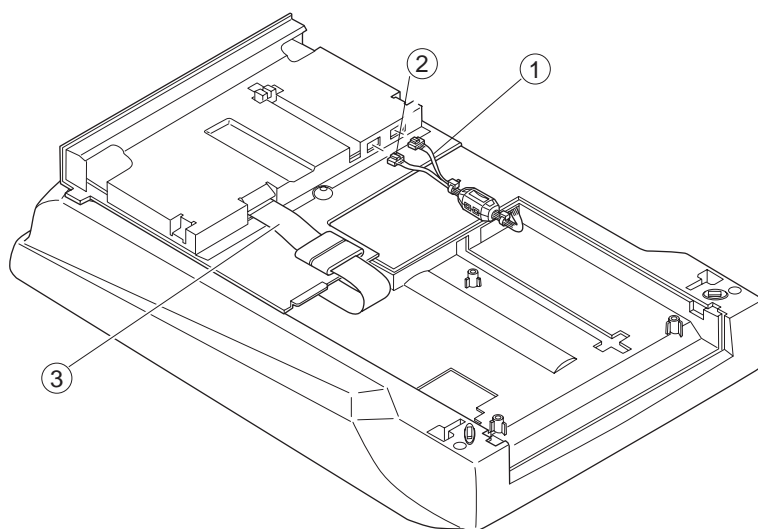

- ① Drive Motor Cable
- ② Button PCB Cable
- ③ Scanning Unit Cable (Flat Cable)

Figure 3-4

B. Removing the Button PCB

- 1) Remove the main PCB.
- 2) Cut two cable clamps to remove the ferrite core.

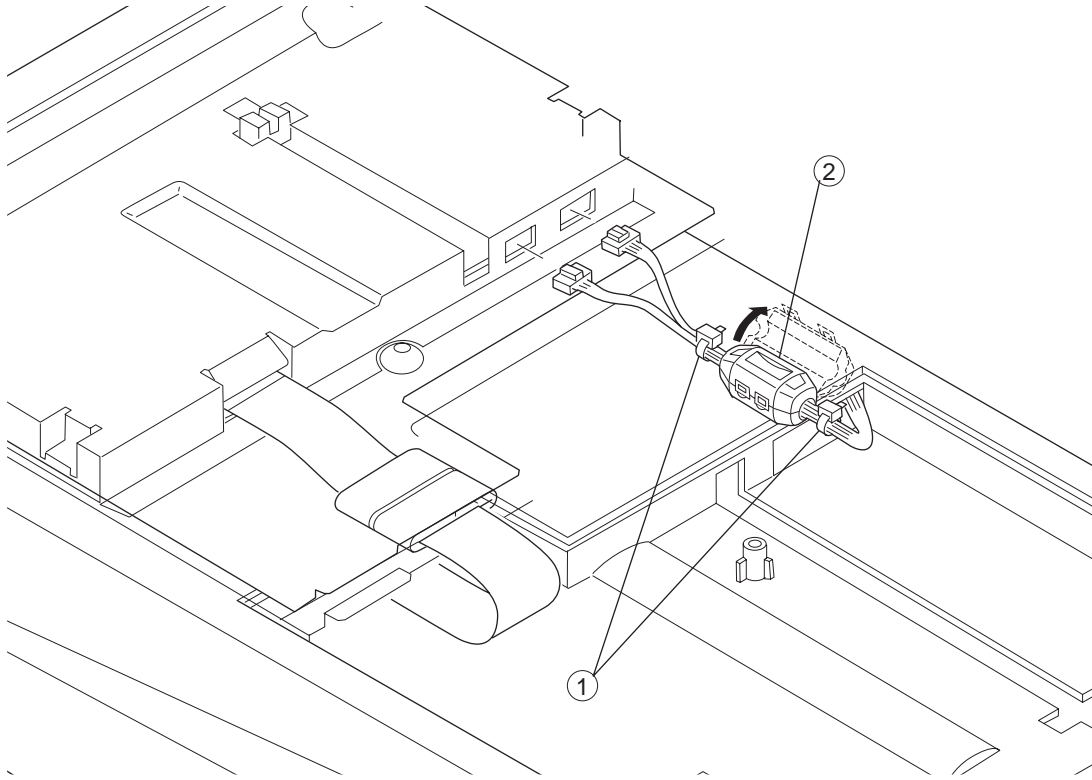

- ① Cable Clamp
- ② Ferrite Core

Figure 3-5

- 3) Remove the top cover and document glass.
- 4) Remove two screws from the cable cover to remove it, then cut two cable clamps.

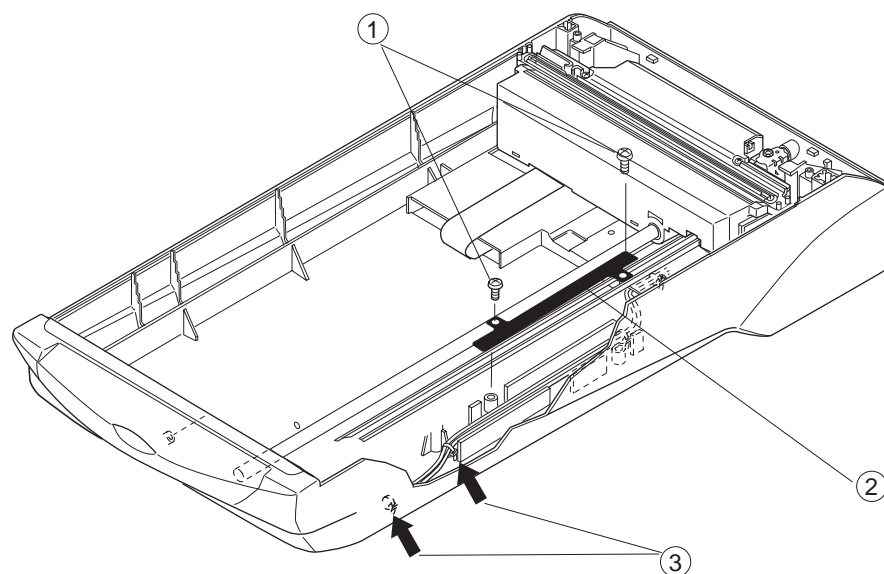

- ① Screw
- ② Cable Cover
- ③ Cable Clamp

Figure 3-6

5) Remove the screw from the button PCB to remove it.

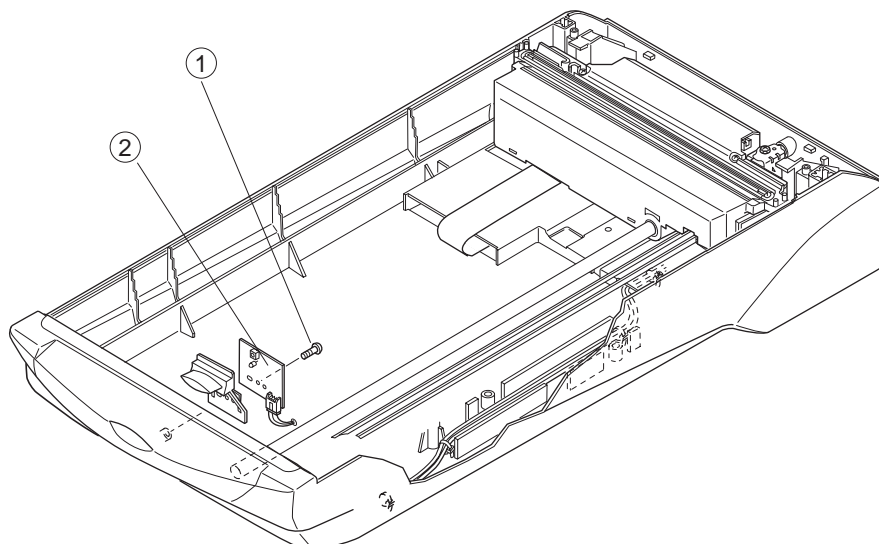

- ① Screw
- ② Button PCB

Figure 3-7

Note: When assembling, make sure to tie the cables for the drive motor and button PCB together with four cable clamps, and attach the ferrite core. (See Figure 3-5 and 3-6)

IV. OPTICAL SYSTEM

A. Removing the Scanning Unit

- 1) Remove the main PCB.
- 2) Remove two cable clamps to remove the ferrite core.
- 3) Remove the top cover and document glass.
- 4) Remove two screws from the cable cover to remove it, then cut two cable clamps.
- 5) Rotate the gear mounted on the drive motor to move the scanning unit away from the home position.

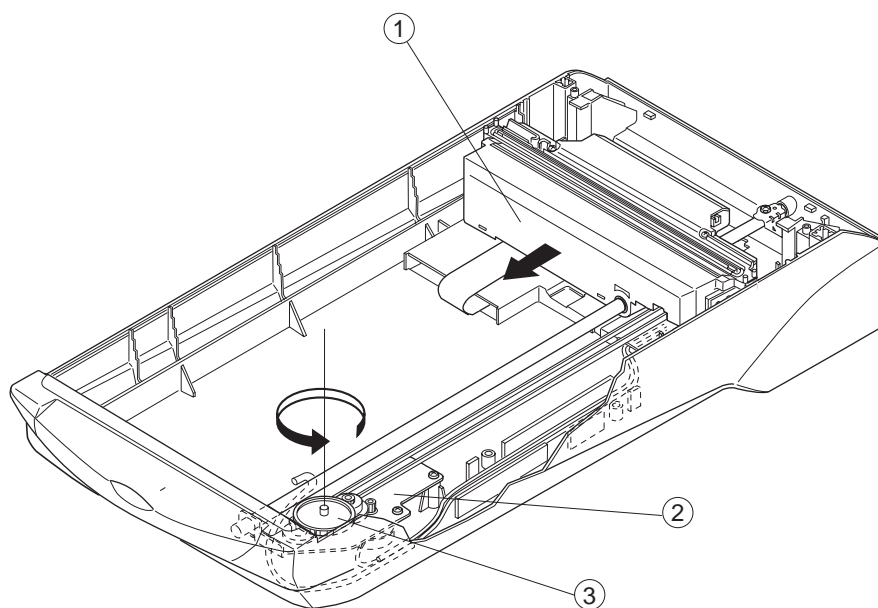

- ① Scanning Unit
- ② Drive Motor
- ③ Gear

Figure 3-8

- 6) Remove two screws that fix the gear plate 2 on the sliding rod to remove the gear plate 2 and spring.

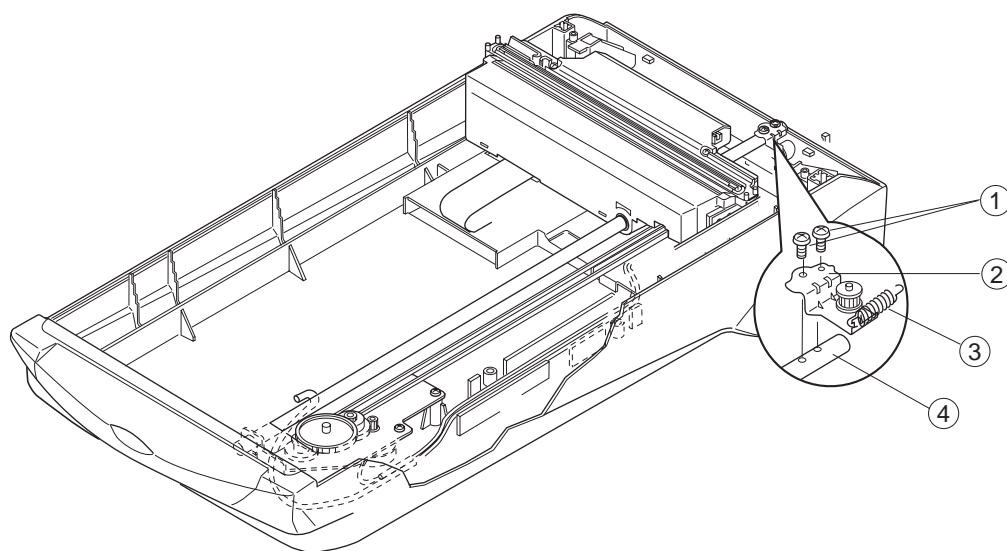

- ① Screw
- ② Gear Plate 2
- ③ Spring
- ④ Sliding Rod

Figure 3-9

Note: When fixing the gear plate 2 on the sliding rod, use the spring to adjust the drive belt tension.

7) Remove the screw that fixes the drive motor on the main frame.

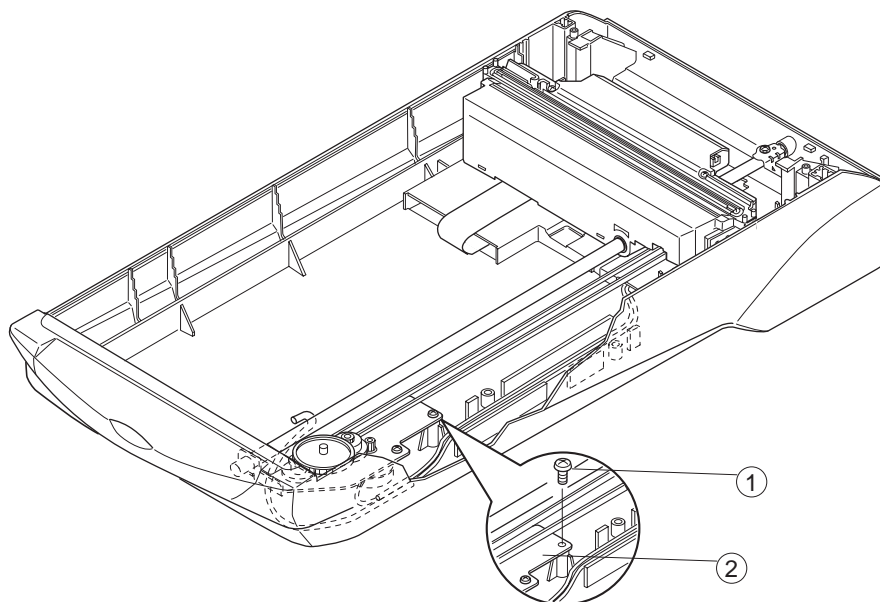

- ① Screw
- ② Drive Motor

Figure 3-10

8) Slide the sliding rod in the arrow direction, then lift with the scanning unit to remove it.

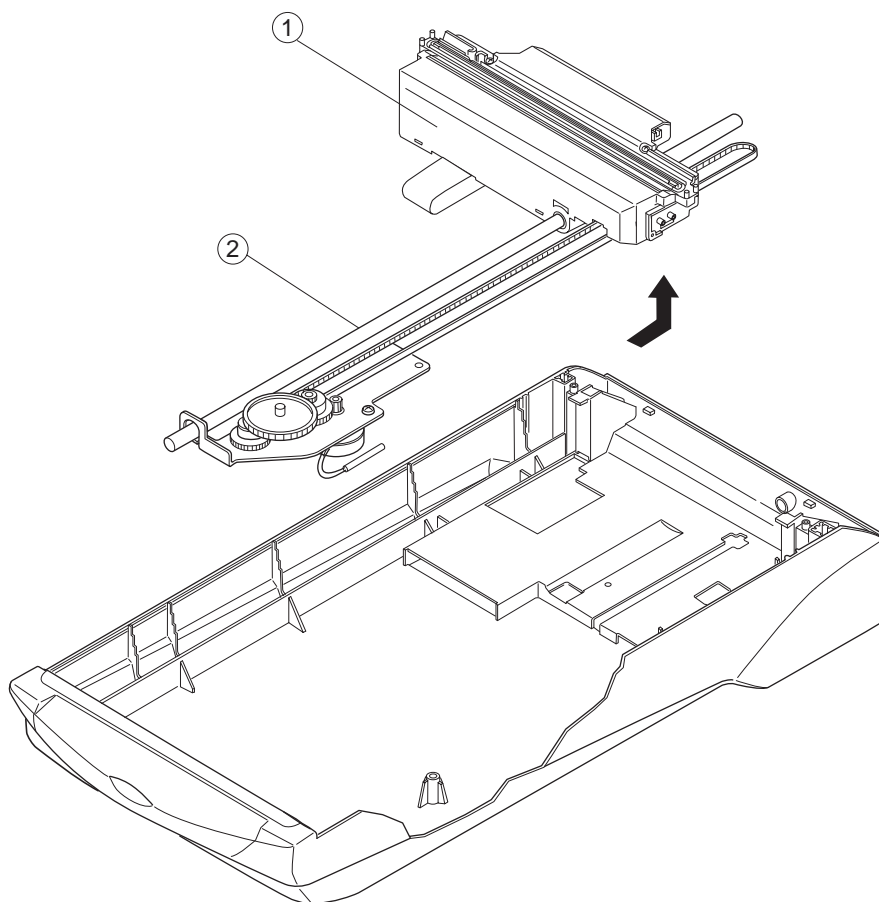

- ① Scanning Unit
- ② Sliding Rod

Figure 3-11

9) Remove the drive belt from the scanning unit.

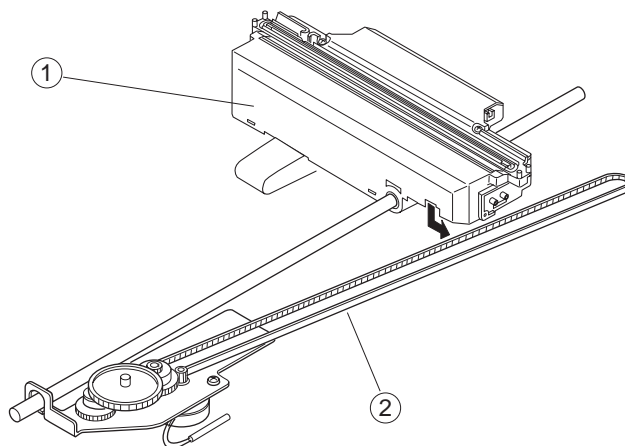

- ① Scanning Unit
- ② Drive Belt

Figure 3-12

Note: Do not remove the flat cable from the scanning unit.

10) Pull out the sliding rod to remove the scanning unit.

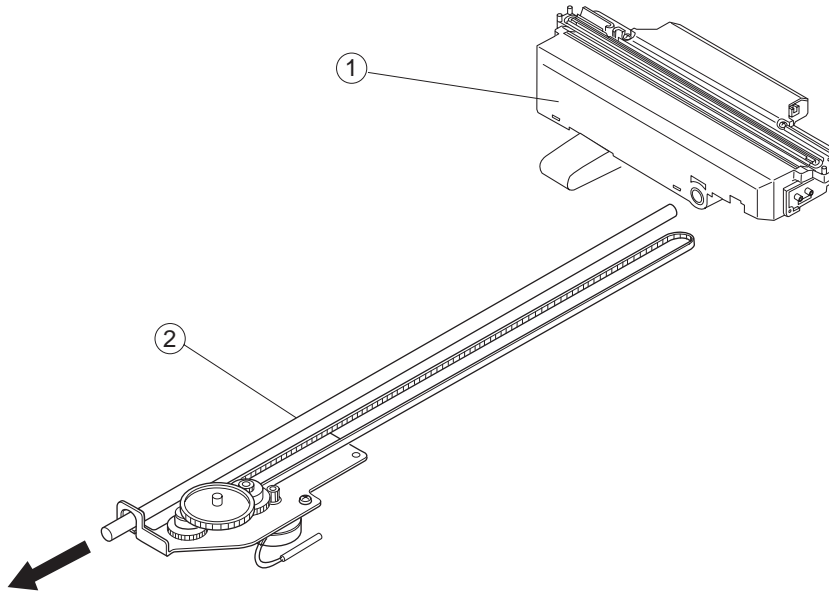

- ① Scanning Unit
- ② Sliding Rod

Figure 3-13

B. Removing the Drive Motor

- 1) Remove the main PCB.
- 2) Remove the top cover and document glass.
- 3) Remove the scanning unit.
- 4) Pull the drive belt through the gear to remove it from the drive motor.

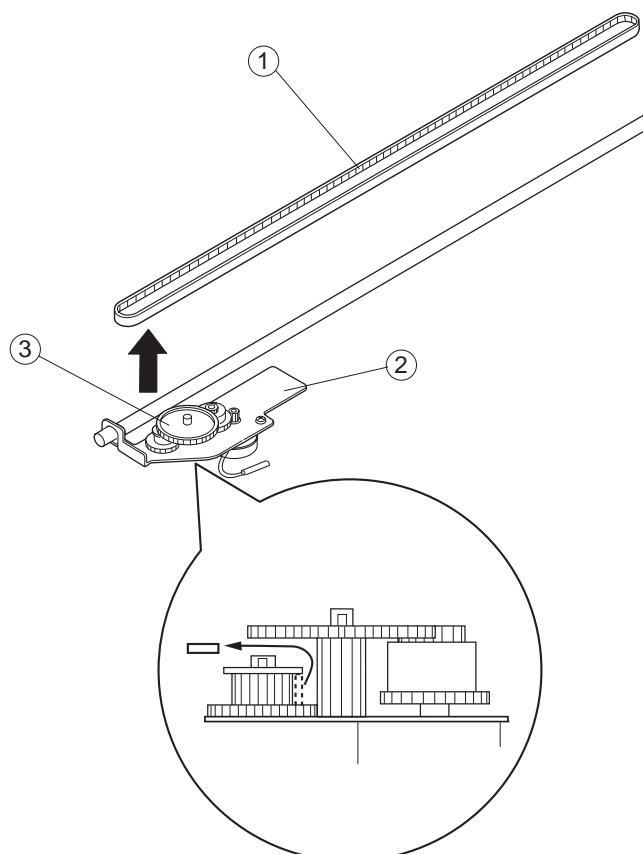

- ① Drive Belt
- ② Drive Motor
- ③ Gear

Figure 3-14

5) Remove the screw that fixes the drive motor on the sliding rod.

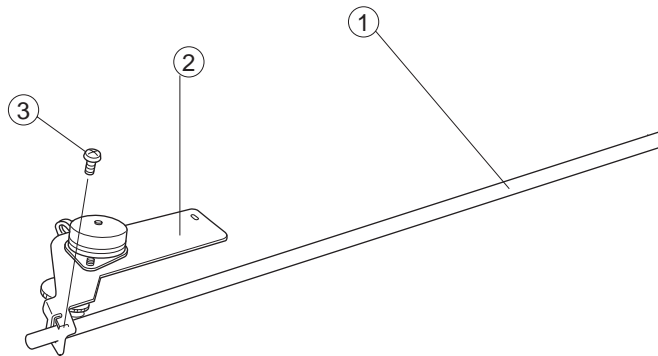

- ① Sliding Rod
- ② Drive Motor
- ③ Screw

Figure 3-15

C. Attaching the Drive Motor

- 1) Apply grease (EM-50L) to the gear on the drive motor as shown by arrows caring not to apply it to the other part.

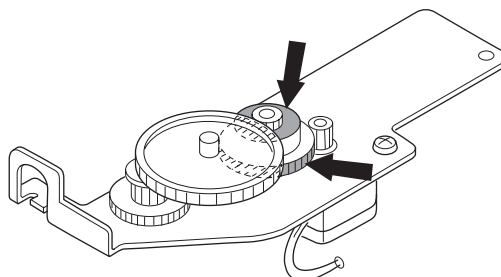

Figure 3-16

- 2) Put the sliding rod into the drive motor and fix them with one screw.
- 3) Pass the drive belt through the gear on the drive motor.
- 4) Attach the scanning unit.

Note: When assembling, make sure to tie the cables for the drive motor and button PCB together with four cable clamps, and attach the ferrite core. (See Figure 3-5 and 3-6)

CHAPTER 4

MAINTENANCE AND SERVICING

I. PERIODICAL REPLACEMENT PARTS	4-1	III. PERIODICAL SERVICING	4-1
II. CONSUMABLE PARTS DURABILITY	4-1	IV. SPECIAL TOOLS	4-1
		V. SOLVENTS AND LUBRICANTS	4-1

I. PERIODICAL REPLACEMENT PARTS

None

II. CONSUMABLE PARTS DURABILITY

None

III. PERIODICAL SERVICING

None

IV. SPECIAL TOOLS

None

V. SOLVENTS AND LUBRICANTS

Grease used for disassembly and reassembly of the scanner.

Name : MOLYKOTE EM-50L

Tool No. : TKC-0955

Usage : To be applied to the gear of the motor assembly.

CHAPTER 5

TROUBLESHOOTING

I. INTRODUCTION	5-1	C. Scanning Unit Movement	
A. Initial Check	5-1	Failure	5-5
B. Others	5-1	D. Poor Image Quality	5-5
II. TROUBLESHOOTING		E. Acoustic Noise	5-5
FLOWCHART	5-2	IV. CANON SCANNER TEST	5-6
A. Power LED Failure	5-2	A. Outline	5-6
B. Communication Failure	5-3	B. Operating Environment	5-6
III. PROBLEM, CAUSE AND		C. Functions	5-7
CORRECTIVE ACTION	5-4	D. Functions Descriptions	5-8
A. Power LED Not Lighting	5-4	E. Error Message	5-16
B. Communication Failure	5-4		

I. INTRODUCTION

A. Initial Check

Check if the operating environment conforms to the following conditions.

- * Line voltage is within $\pm 10\%$ of the rated value.
- * Ambient temperature and humidity conform to the operating environment. (Refer to CHAPTER 1, I. SPECIFICATIONS)
- * The scanner is not setup near a water faucet, boiler, humidifier, open flame, or in dusty place.
- * The scanner is not exposed to direct sunlight. If it is inevitable to setup in a sunny place, hang a curtain to block direct sunlight.
- * The scanner is setup in a well-ventilated place.

B. Others

Moving a scanner from a cold place to a warm place can cause condensation on the metal parts, resulting in a faulty operation.

II. TROUBLESHOOTING FLOWCHART

A. Power LED Failure

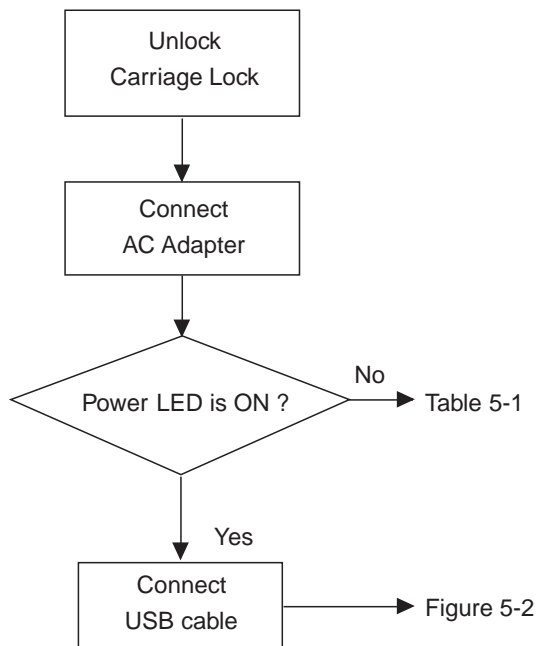
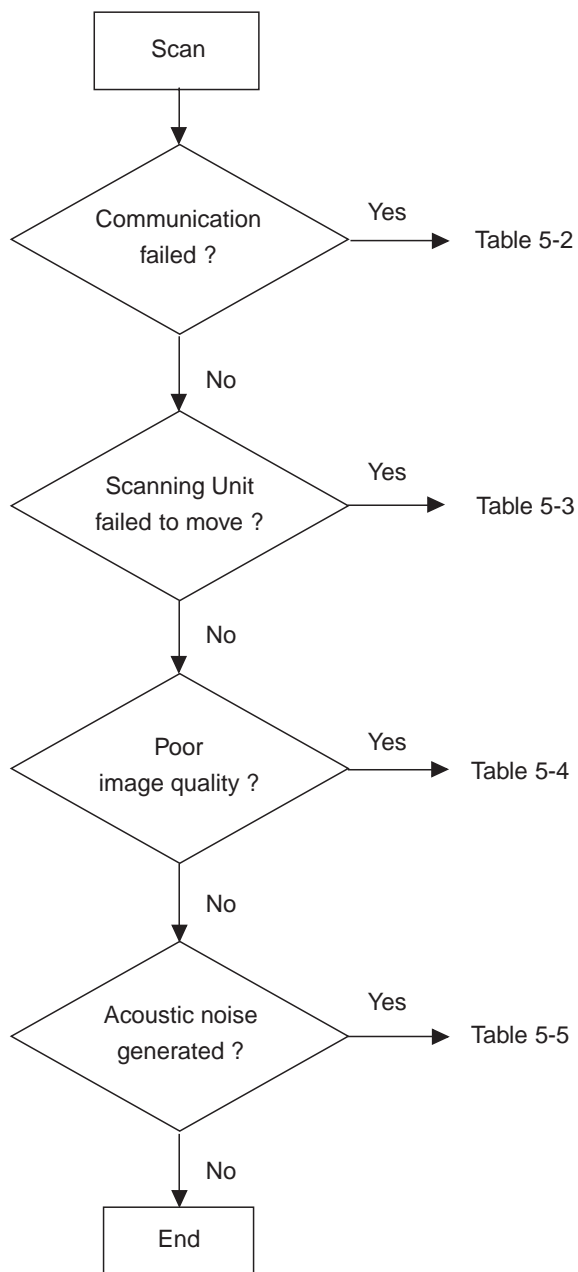

Figure 5-1

B. Communication Failure**Figure 5-2**

III. PROBLEM, CAUSE AND CORRECTIVE ACTION

D1230U/D2400U may have the following five problems.

- * Power LED not lighting
- * Communication failure
- * Scanning unit movement failure
- * Poor image quality
- * Acoustic noise

A. Power LED Not Lighting

Possible Cause	Related Parts	Check Method	Corrective Action
AC adapter is unplugged from the outlet	None	Visual check	Plug the AC adapter into the outlet
AC Adapter cable is disconnected from the scanner	None	Visual check	Connect the AC adapter cable to the power connector on the scanner
AC adapter output voltage failure	AC Adapter	Output voltage (+12V) check	Replace the AC adapter
Main PCB failure	Main PCB	Tester check (+12V, GND)	Replace the main PCB
Main PCB connection failure	None	Visual check	Properly connect the main PCB

Table 5-1

B. Communication Failure

Possible Cause	Related Parts	Check Method	Corrective Action
USB cable connection failure	USB cable	Visual check	Connect the USB cable properly
Scanner communication failure	Main PCB	Trial replacement	Replace the main PCB
Scanning unit failure	Scanning unit	Trial replacement	Replace the scanning unit

Table 5-2

C. Scanning Unit Movement Failure

Possible Cause	Related Parts	Check Method	Corrective Action
Drive belt broken or worn	Drive belt	Trial replacement	Replace the drive belt
Gears broken or worn	Gear plate 2	Trial replacement	Replace the gear plate 2
Start button failure	Button PCB	Trial replacement	Replace the button PCB
Drive motor failure	Motor assembly	Trial replacement	Replace the motor assembly

Table 5-3**D. Poor Image Quality**

Possible Cause	Related Parts	Check Method	Corrective Action
Scanning lamp is dark	Scanning unit	Visual check	Replace the scanning unit
Dirt on document glass	Document glass	Visual check	Clean the document glass
Main PCB failure	Main PCB	Trial replacement	Replace the main PCB
CCD PCB failure	Scanning unit	Trial replacement	Replace the scanning unit

Table 5-4**E. Acoustic Noise**

Possible Cause	Related Parts	Check Method	Corrective Action
Motor assembly failure	Motor assembly	Trial replacement	Replace the motor assembly
Main PCB failure	Main PCB	Trial replacement	Replace the main PCB
Scanning unit failure	Scanning unit	Trial replacement	Replace the scanning unit
Dirt on sliding rod	None	Visual check	Clean the sliding rod
Reference sheet is improperly positioned	Document glass	Trial replacement	Replace the document glass

Table 5-5

IV. CANON SCANNER TEST

A. Outline

Canon Scanner Test is a utility software to check if faulty operation of CanoScan D1230U/D2400U is due to the hardware or the communication with the host computer.

Windows : scnchk1.exe (English or Japanese is switched according to the language to be used in Windows.)

Macintosh : chk12302400e (English)
chk12302400j (Japanese)

B. Operating Environment

The following environment is required for operating the Canon Scanner Test.

Windows platform

- * CanoScan D1230U/D2400U
- * PC/AT Compatibles (Pentium or later)
- * Windows 98 OS
- * D1230U/D2400U Device Driver

Macintosh platform

- * CanoScan D1230U/D2400U
- * Power Macintosh
- * Macintosh OS (Version 8.5 or later)
- * D1230U/D2400U Device Driver

Note: Install D1230U/D2400U device driver before using the Canon Scanner Test.
--

C. Functions

1. USB Information (Windows only)

Scanner information connected to the USB port on the PC of Windows is displayed.

2. Scanner Information

Scanner information connected to the PC is displayed.

3. Scanner Self Test

CanoScan D1230U/D2400U self test is executed.

4. Scan

An image is scanned at any resolution and saved as an image file in the folder of Canon Scanner Test.

5. Film Scan

35mm sleeve negative film is scanned by FAU lamp and Infrared LED with FARE function when using FAU, then saved as two image files in the folder of Canon Scanner Test. The film is set in the sleeve film holder 1 and scanned at 1200 dpi fixed.

This command is for D2400U only.

Note: Calibration function is gray out and unable to click for D1230U/D2400U.

D. Functions Descriptions

1. USB Information (Windows only)

Select "USB Information" from the "Function" menu to display as shown in Figure 5-3 (Windows).

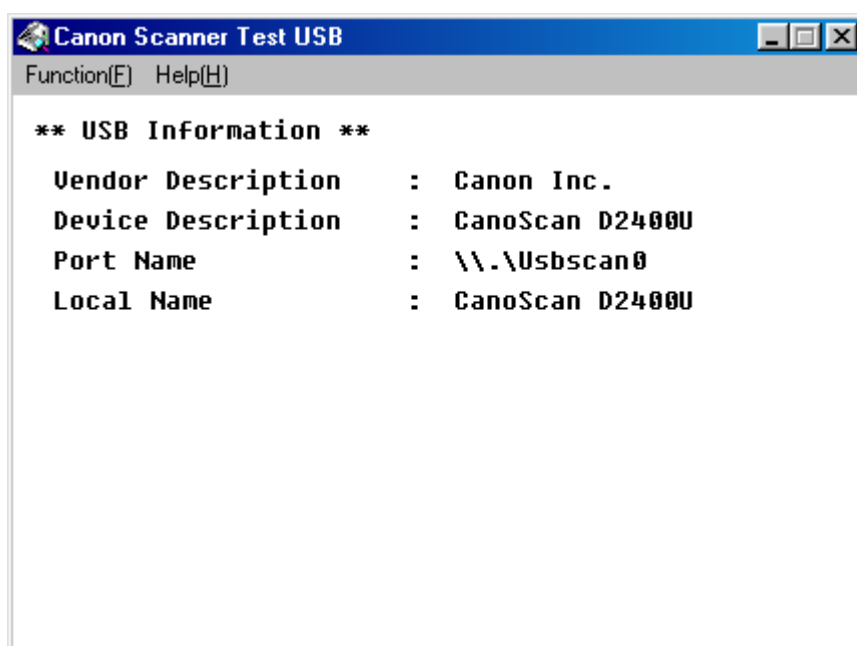

Figure 5-3

- * Vendor Description : Manufacturer name of the scanner "Canon Inc."
- * Device Description : Product name of the scanner "CanoScan D1230U" or "CanoScan D2400U"
- * Port Name : Port name of the scanner recognized by Windows
- * Local Name : Product name of the scanner "CanoScan D1230U" or "CanoScan D2400U"

2. Scanner Information

Select "Scanner information" from the "Function" menu to display as shown in Figure 5-4 (Windows), Figure 5-5 (Macintosh).

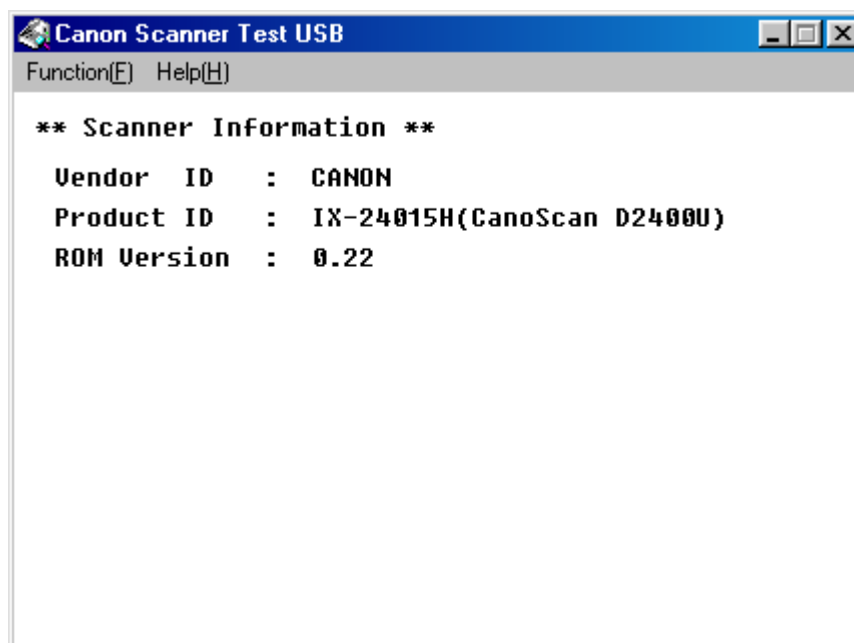

Figure 5-4

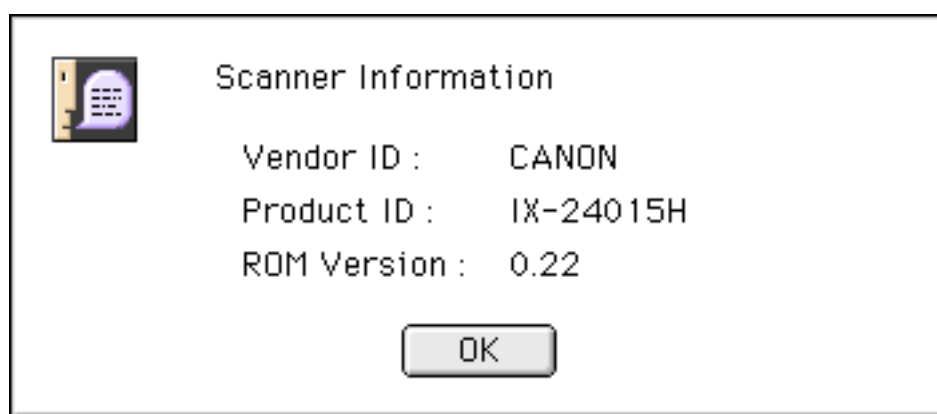

Figure 5-5

- * Vendor ID : Manufacturer name of the scanner "CANON"
- * Product ID : "IX-24015H"(CanoScan D2400U) or "IX-12145G" (CanoScan D1230U)
- * ROM Version : Firmware version of the control program of the scanner

3. Scanner Self Test

Select "Scanner self test" from the "Function" menu to display as shown in Figure 5-6 (Windows), Figure 5-7 (Macintosh).

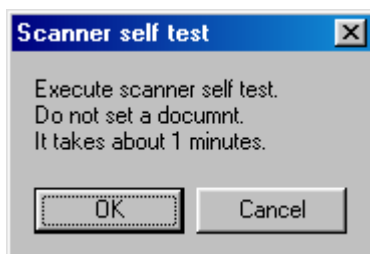

Figure 5-6

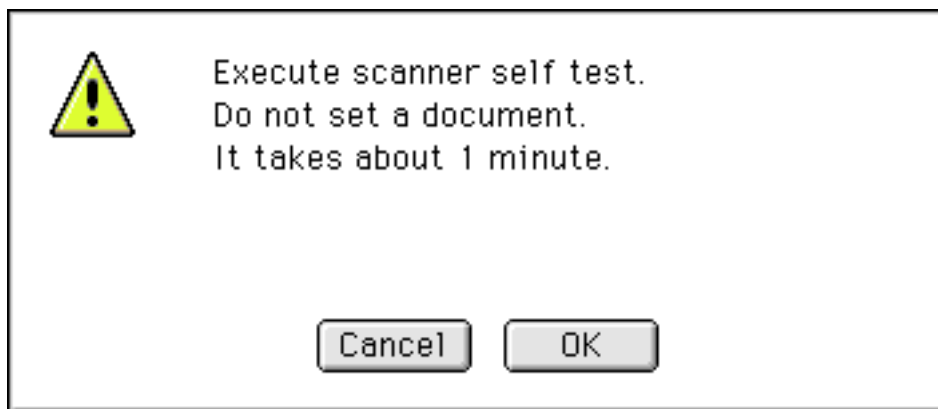

Figure 5-7

Click “OK” to start scanner self test. When it is completed normally, a dialog is displayed as shown in Figure 5-8 (Windows), Figure 5-9 (Macintosh).

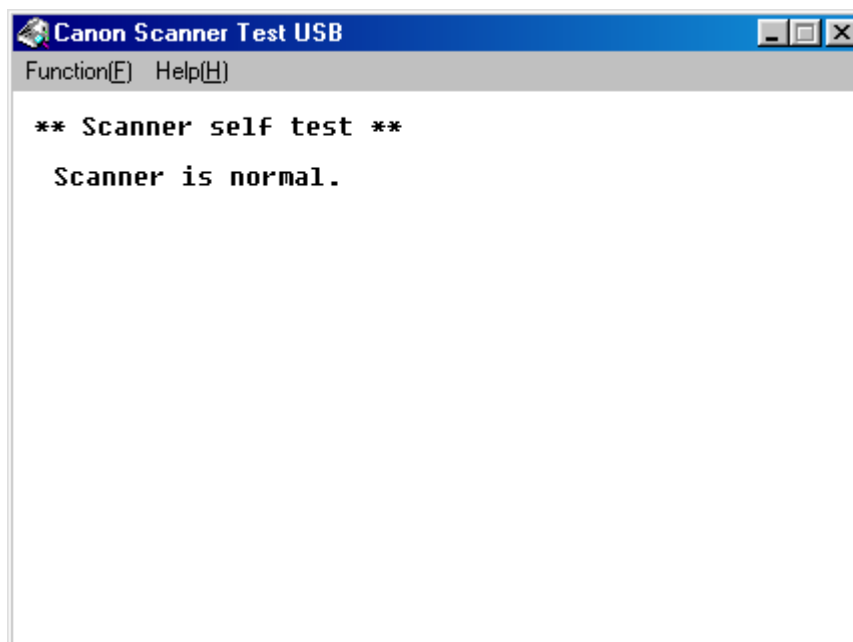

Figure 5-8

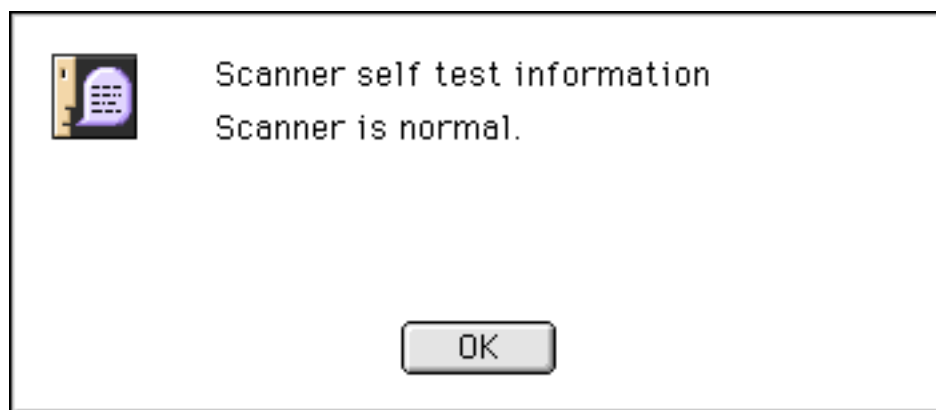

Figure 5-9

When an error occurs, refer to “E. Error Message” to take a corrective action.

4. Scan

Select "Scan" from the "Function" menu to display as shown in Figure 5-10 (Windows), Figure 5-11 (Macintosh).

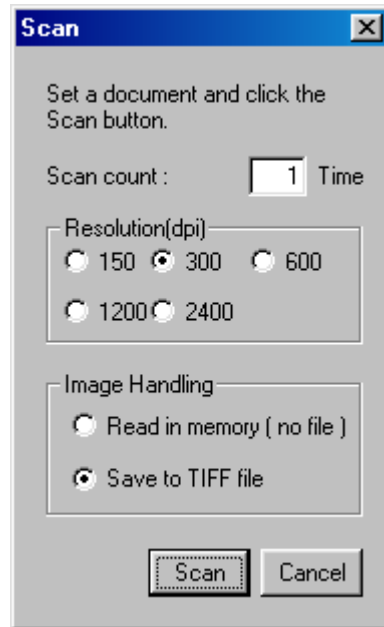

Figure 5-10

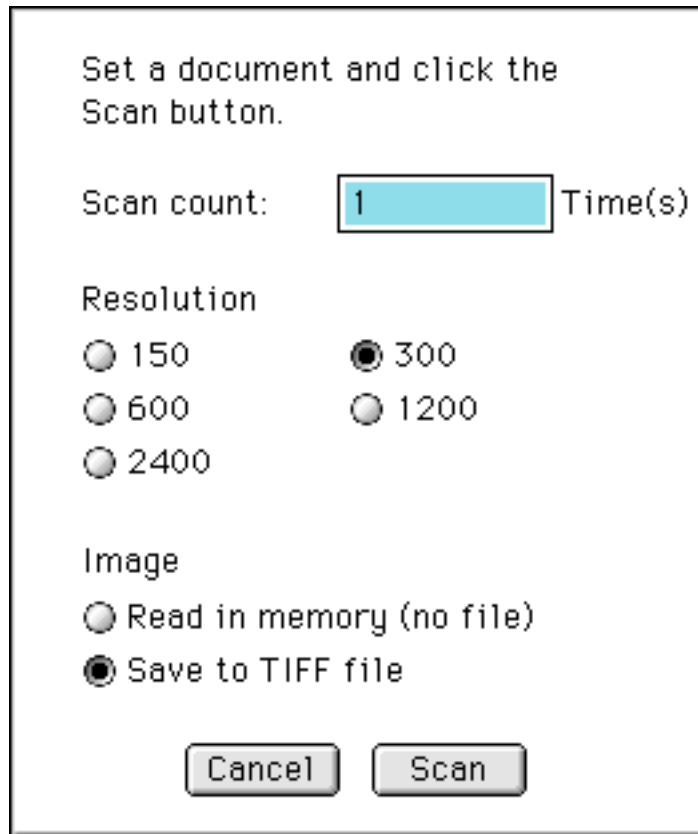

Figure 5-11

* Scan count

Set a number from 1 to 100.

* Resolution (dpi)

When the resolution for scanning an image is selected at 150 or 300 dpi, whole document glass area is scanned. When selected at 600, 1200, or 2400 dpi, 40mm forwarded area from the reference sheet of the document glass is scanned.

* Image handling

When "Read in memory (no file)" is selected, the image is read into the memory, then abandoned after readout. When "Save to TIFF file" is selected for handling an scanned image, the file of "img0.tif" is saved in the folder of the Canon Scanner Test. When scan count is set at 2 or more, the file of "img0.tif", "img1.tif", "img2.tif" ... are saved.

File space to be saved is as follows.

150 dpi : 6.5 MB

300 dpi : 26 MB

600 dpi : 15 MB

1200 dpi : 60 MB

2400 dpi : 240 MB

Note : Confirm before scanning that the available disk space on the HDD in which the Canon Scanner Test is installed exceeds above file space.

5. Film Scan

Select "Film Scan" from the "Function" menu to display as shown in Figure 5-12 (Windows), Figure 5-13 (Macintosh).

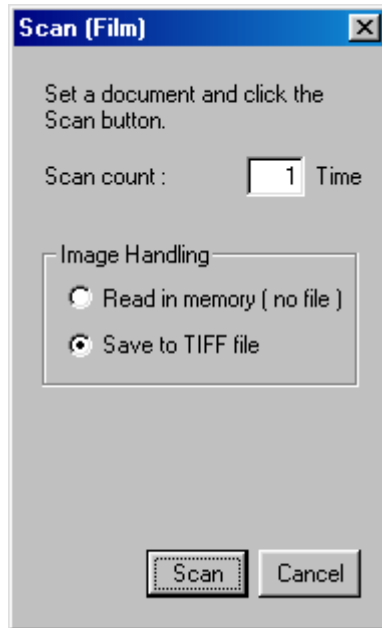

Figure 5-12

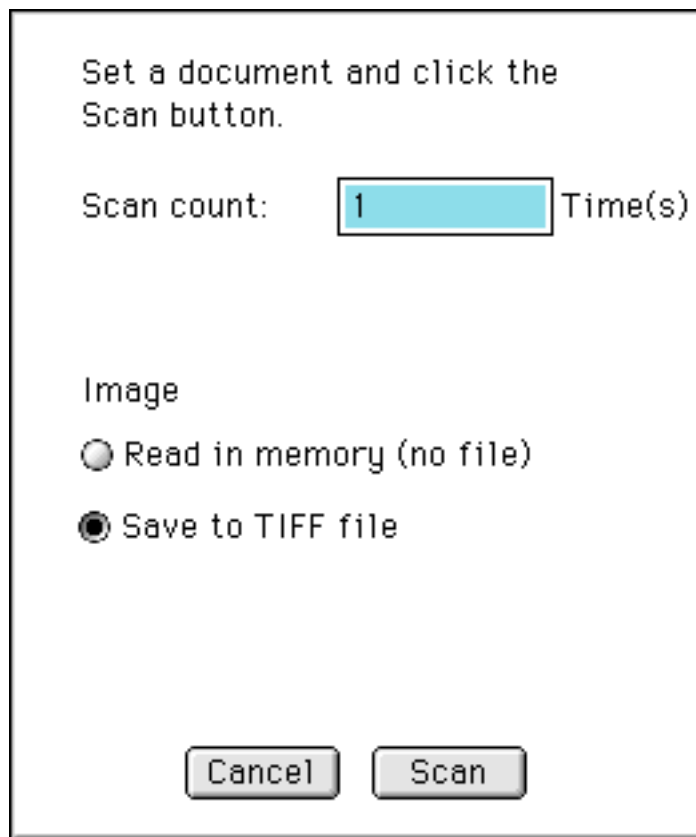

Figure 5-13

* Scan count

Set a number from 1 to 100. When 2 or more is set and "Save to TIFF file" is selected, only a file of specified count is saved.

* Image handling

When "Read in memory (no file)" is selected, the image is read into the memory, then abandoned after readout. When "Save to TIFF file" is selected, two image files scanned by FAU lamp and infrared LED are saved. "Color24.tif" and "IR.tif" are saved in the folder of the Canon Scanner Test. IR.tif is an image of only dirt or dust on the film when FARE function is used. If FARE function does not normally operate, IR.tif image appears all black.

File space to be saved is as follows.

Color24.tif (1200 dpi) : 5.6 MB

IR.tif (1200 dpi) : 5.6 MB

E. Error Message

1. "Scanner is disconnected or locked."

Cause 1 : Carriage lock is locked.

Corrective action : Unlock the carriage lock.

Cause 2 : USB cable is not properly connected.

Corrective action : Connect the USB cable to the host computer and the scanner properly.

Cause 3 : Scanner is not detected by the host computer.

Corrective action : Refer to the "II. Troubleshooting Flowchart".

2. "Scanner is disconnected."

Cause 1 : Scanner is not connected to the host computer.

Corrective action : Refer to the "II. Troubleshooting Flowchart".

Cause 2 : Device driver is not installed.

Corrective action : Install CanoScan D1230U/D2400U device driver.

3. "Insupportable scanner is connected."

Cause : The connected scanner is not supported by the Canon Scanner Test.

Corrective Action : Connect CanoScan D1230U/D2400U.

4. "Unable to find the scanner. Check if the cables are connected properly."

Cause : Scanner is not detected by the host computer.

Corrective Action : Refer to the "II. Troubleshooting Flowchart".

5. "Failed to read scanner information."

Cause : Scanner is not detected by the host computer.

Corrective Action : Refer to the "II. Troubleshooting Flowchart".

6. "Failed to create a file." "Failed to open a file." "Failed to close a file." "Failed to write-in a file."

Cause : Canon Scanner Test is started from a CD-ROM or write-protected HDD.

Corrective Action : Copy the Canon Scanner Test on a writable HDD to use.

7. "Unable to communicate with scanner. Check if scanner is powered ON or USB cable is connected properly."

Cause : Scanner is not detected by the host computer.

Corrective Action : Refer to the "II. Troubleshooting Flowchart".

8. "Scanner has problem." "Failed to execute scanner self test."

Cause : Scanner is not detected by the host computer.

Corrective Action : Refer to the "II. Troubleshooting Flowchart".

9. "Failed to allocate memory."

Cause : Scanner is not detected by the host computer.

Corrective Action : Refer to the "II. Troubleshooting Flowchart".

CHAPTER 6

PARTS CATALOG

FIGURE 001	6-2
FIGURE 100	6-4

FIGURE 200	6-6
FIGURE 300	6-8

CanoScan D1230U / CanoScan D2400U

FIGURE 001

ACCESSORY

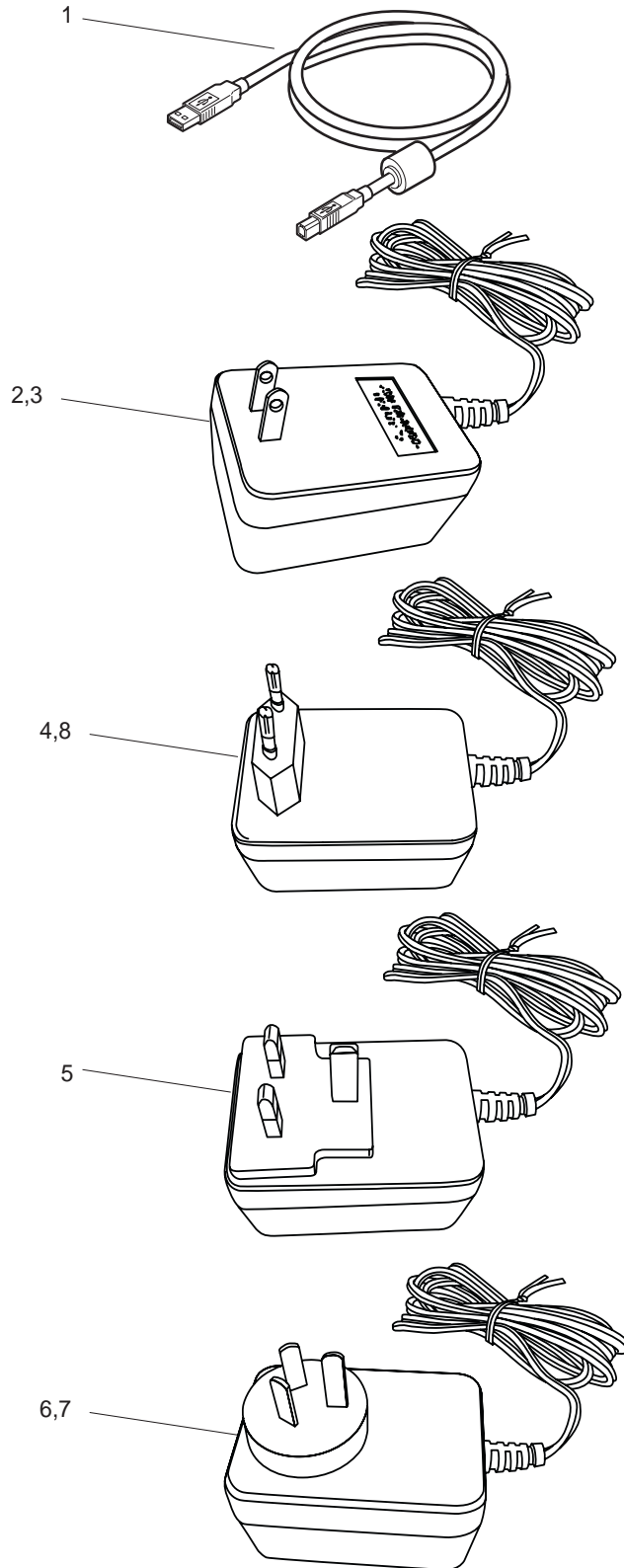

FIGURE & KEY NO.	PART NUMBER	R A N K	Q' T Y	DESCRIPTION	SERIAL NUMBER/REMARKS
001-01	NIC-BXDC-002		1	CABLE, USB	
02	NIP-WFS0-735		1	ADAPTOR, AC	JAPAN
03	NIP-WFS0-737		1	ADAPTOR, AC	USA, CAN, LA
04	NIP-WFS0-738		1	ADAPTOR, AC	EUR
05	NIP-WFS0-739		1	ADAPTOR, AC	UK, HK
06	NIP-WFS0-740			ADAPTOR, AC	AUS, SPL
07	NIP-WFS0-741			ADAPTOR, AC	MLC
08	NIP-WFS0-742			ADAPTOR, AC	KOR

FIGURE 100

D1230U

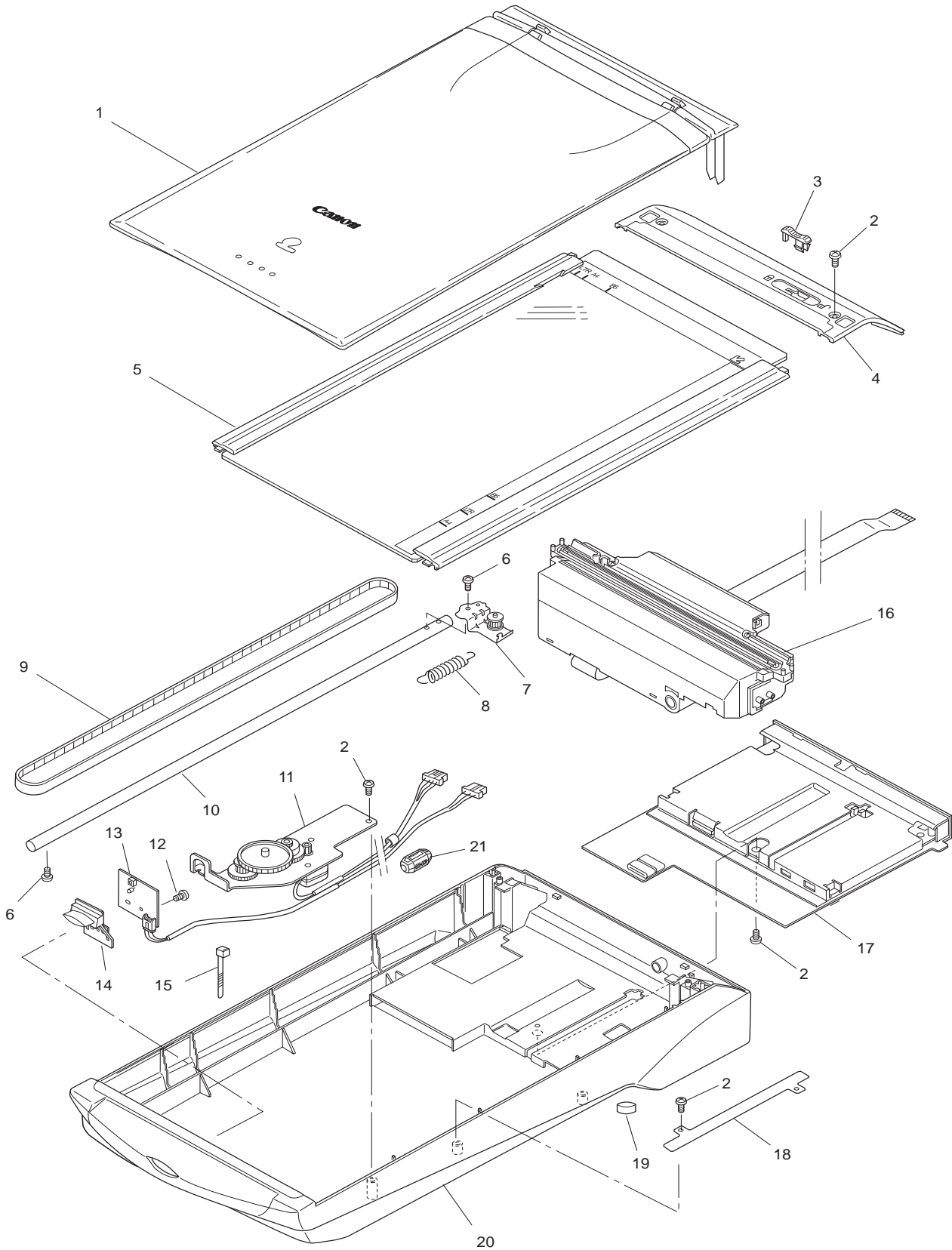

FIGURE & KEY NO.	PART NUMBER	RANK	QTY	DESCRIPTION	SERIAL NUMBER/REMARKS
100-01	NIA-YFSC-290		1	DOCUMENT COVER ASSEMBLY	
02	NIS-F300-872		8	SCREW, M3X8, SELF-TAPPING	
03	NIP-N339-000		1	LOCK, CARRIAGE	
04	NIP-N226-900		1	COVER, TOP	
05	NIA-YFSC-224		1	PLATEN GLASS ASSEMBLY	
06	NIS-M300-882		3	SCREW, M3X8, BH	
07	NIA-YFSC-317		1	PLATE, GEAR 2	
08	NIM-L103-700		1	SPRING	
09	NIB-LHTS-F18		1	BELT, DRIVE, RUBBER	
10	NIM-U102-300		1	SLIDING ROD	
11	NIA-YFSC-223		1	MOTOR ASSEMBLY	
12	NIS-X000-700		1	SCREW, M3X8, SELF-TAPPING	
13	NIA-YFSC-268		1	BUTTON PCB ASSEMBLY	
14	NIP-N502-100		1	BUTTON, FUNCTION	
15	NIP-N400-300		4	CLAMP, CABLE	
16	NIA-YFSC-236		1	CARRIAGE ASSEMBLY	
17	NIA-YFSC-316		1	MAIN PCB ASSEMBLY	
18	NIP-S200-100		1	COVER, CABLE	
19	NIR-C201-200		4	FOOT, RUBBER	
20	NPN		1	FRAME, MAIN	
21	NPN		1	CORE, FERRITE	

FIGURE 200

D2400U

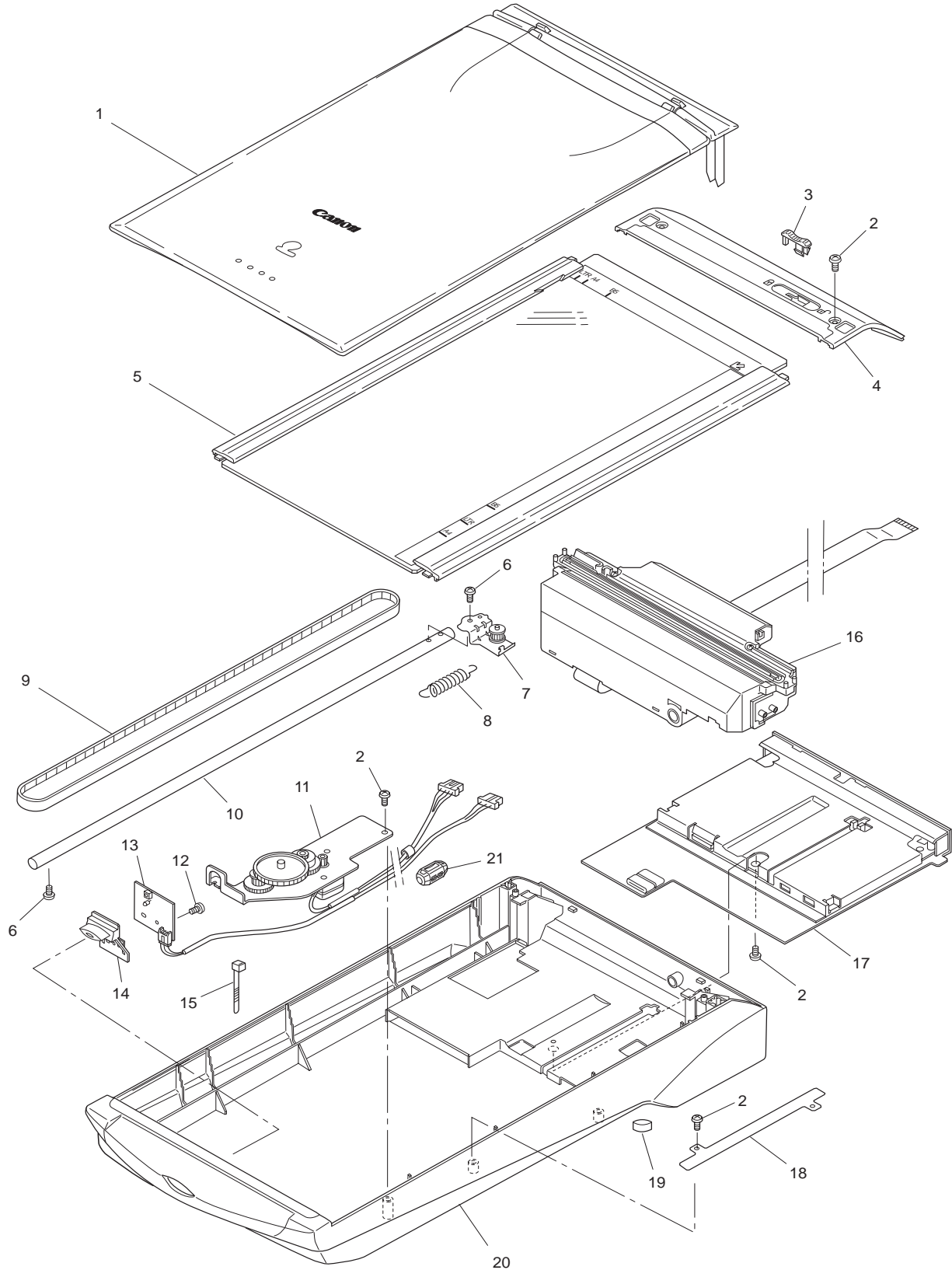

FIGURE & KEY NO.	PART NUMBER	RANK	QTY	DESCRIPTION	SERIAL NUMBER/REMARKS
200-01	NIA-YFSC-360		1	DOCUMENT COVER ASSEMBLY	
02	NIS-F300-872		8	SCREW, M3X8, SELF-TAPPING	
03	NIP-N346-500		1	LOCK, CARRIAGE	
04	NIP-N227-100		1	COVER, TOP	
05	NIA-YFSC-253		1	PLATEN GLASS ASSEMBLY	
06	NIS-M300-882		3	SCREW, M3X8, BH	
07	NIA-YFSC-314		1	PLATE, GEAR 2	
08	NIM-L103-700		1	SPRING	
09	NIB-LHTS-F18		1	BELT, DRIVE, RUBBER	
10	NIM-U102-300		1	SLIDING ROD	
11	NIA-YFSC-251		1	MOTOR ASSEMBLY	
12	NIS-X000-700		1	SCREW, M3X8, SELF-TAPPING	
13	NIA-YFSC-268		1	BUTTON PCB ASSEMBLY	
14	NIP-YFSC-377		1	BUTTON, FUNCTION	
15	NIP-N400-300		4	CLAMP, CABLE	
16	NIA-YFSC-255		1	CARRIAGE ASSEMBLY	
17	NIA-YFSC-313		1	MAIN PCB ASSEMBLY	
18	NIP-S200-100		1	COVER, CABLE	
19	NIR-C201-200		4	FOOT, RUBBER	
20	NPN		1	FRAME, MAIN	
21	NPN		1	CORE, FERRITE	

FIGURE 300

FAU-S12 / FAU-S13

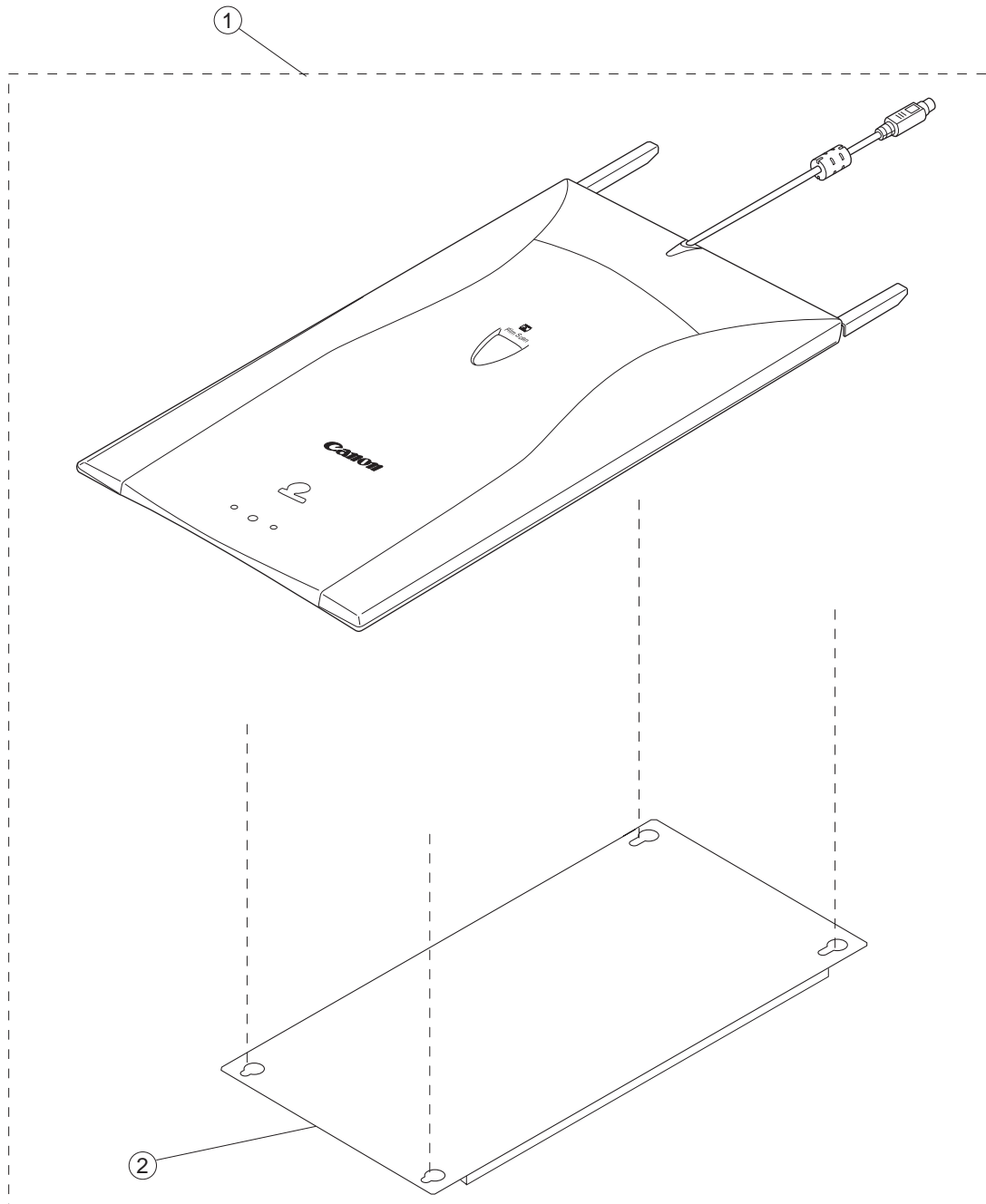
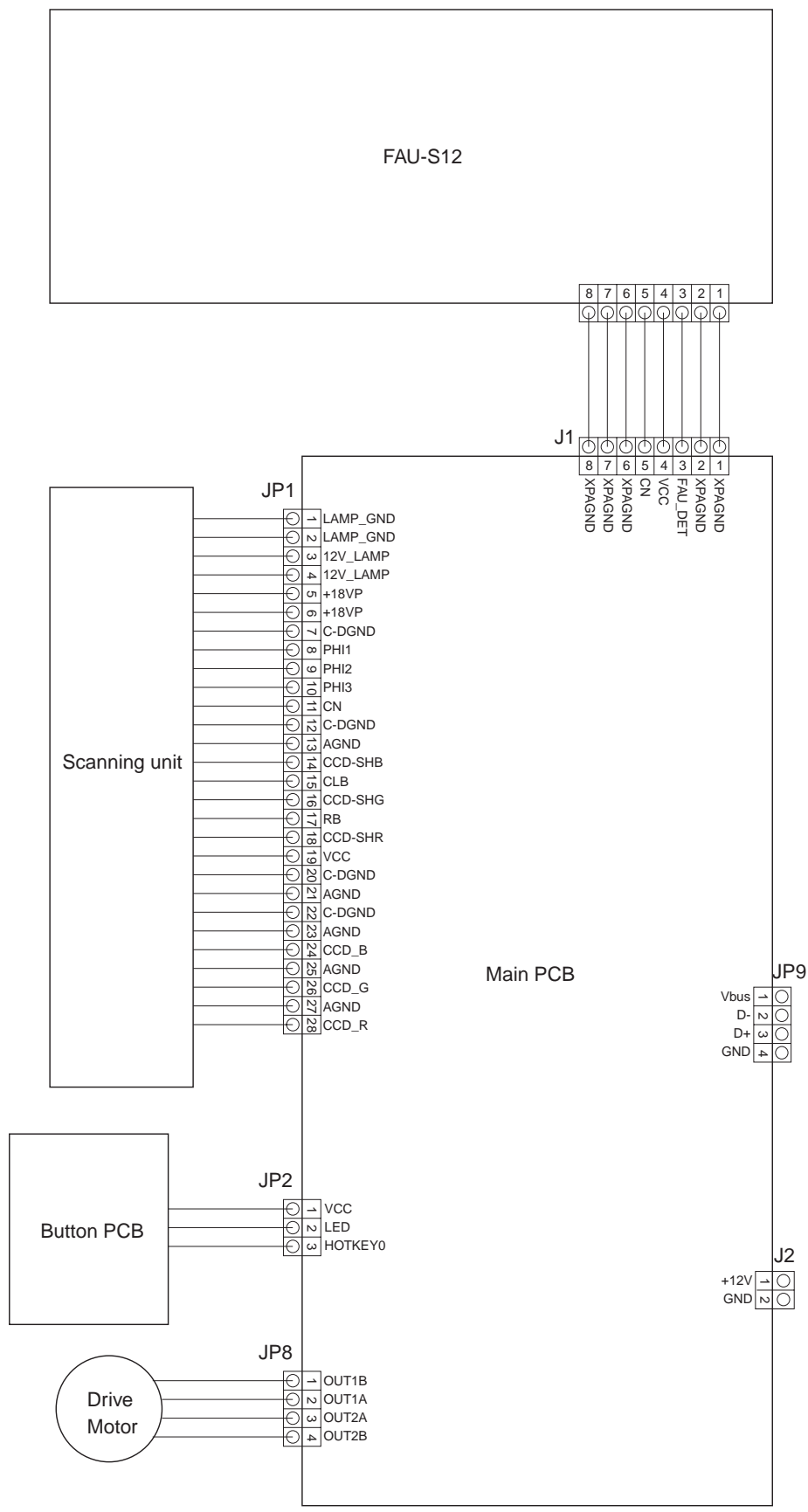

FIGURE & KEY NO.	PART NUMBER	R A N K	Q' T Y	DESCRIPTION	SERIAL NUMBER/REMARKS
300-01	NIA-YFSC-331		1	FILM ADAPTOR UNIT	FAU-S12
	NIA-YFSC-332		1	FILM ADAPTOR UNIT	FAU-S13
02	NIA-YFSC-261		1	COVER, PROTECTIVE	

APPENDIX

I. GENERAL CIRCUIT DIAGRAM (CanoScan D1230U)	A-1	III. MAIN PCB CIRCUIT DIAGRAM (CanoScan D1230U)	A-3
II. GENERAL CIRCUIT DIAGRAM (CanoScan D2400U)	A-2	IV. MAIN PCB CIRCUIT DIAGRAM (CanoScan D2400U)	A-10

I. GENERAL CIRCUIT DIAGRAM (CanoScan D1230U)



II. GENERAL CIRCUIT DIAGRAM (CanoScan D2400U)

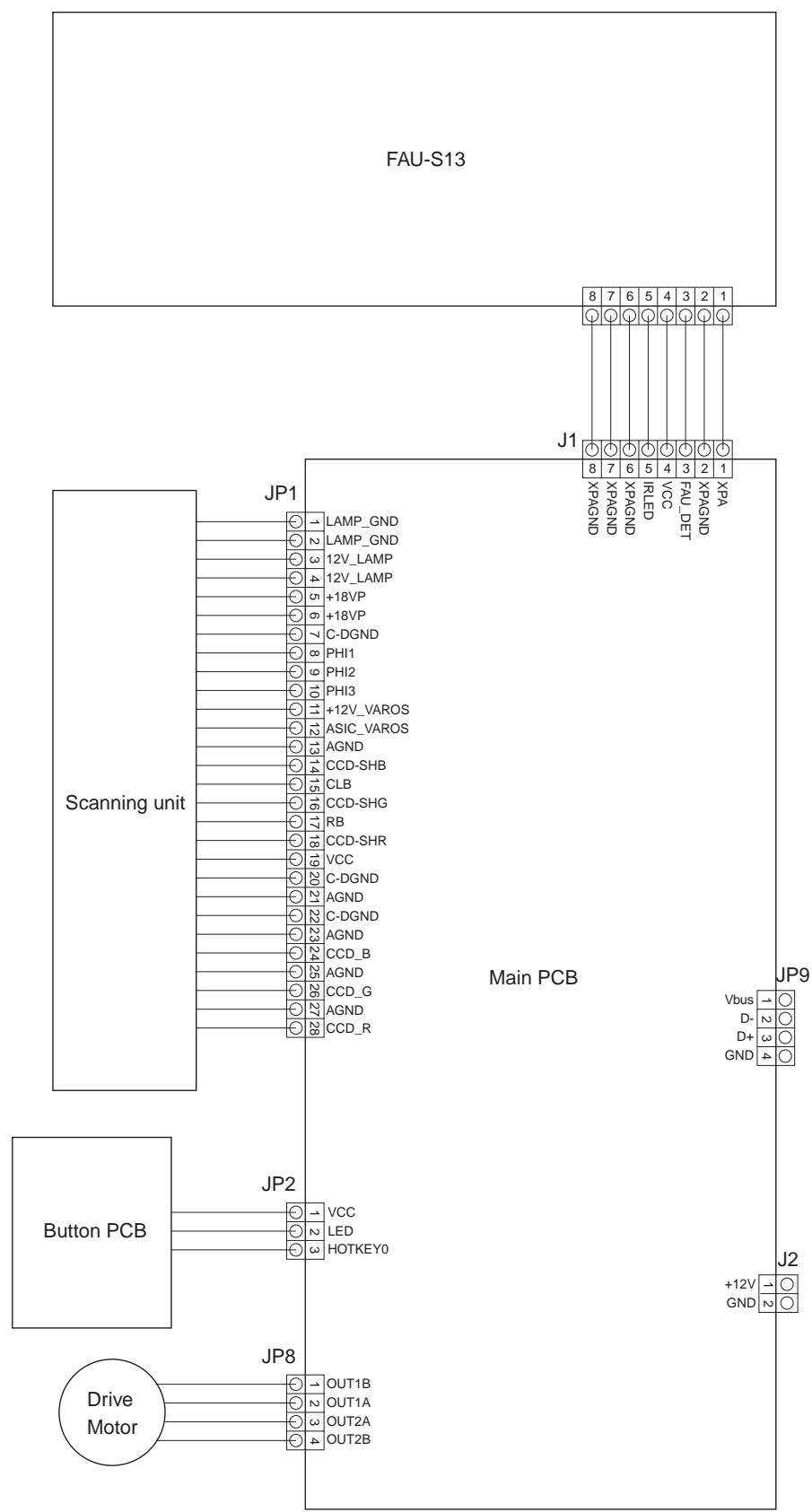

III. MAIN PCB CIRCUIT DIAGRAM (CanoScan D1230U)

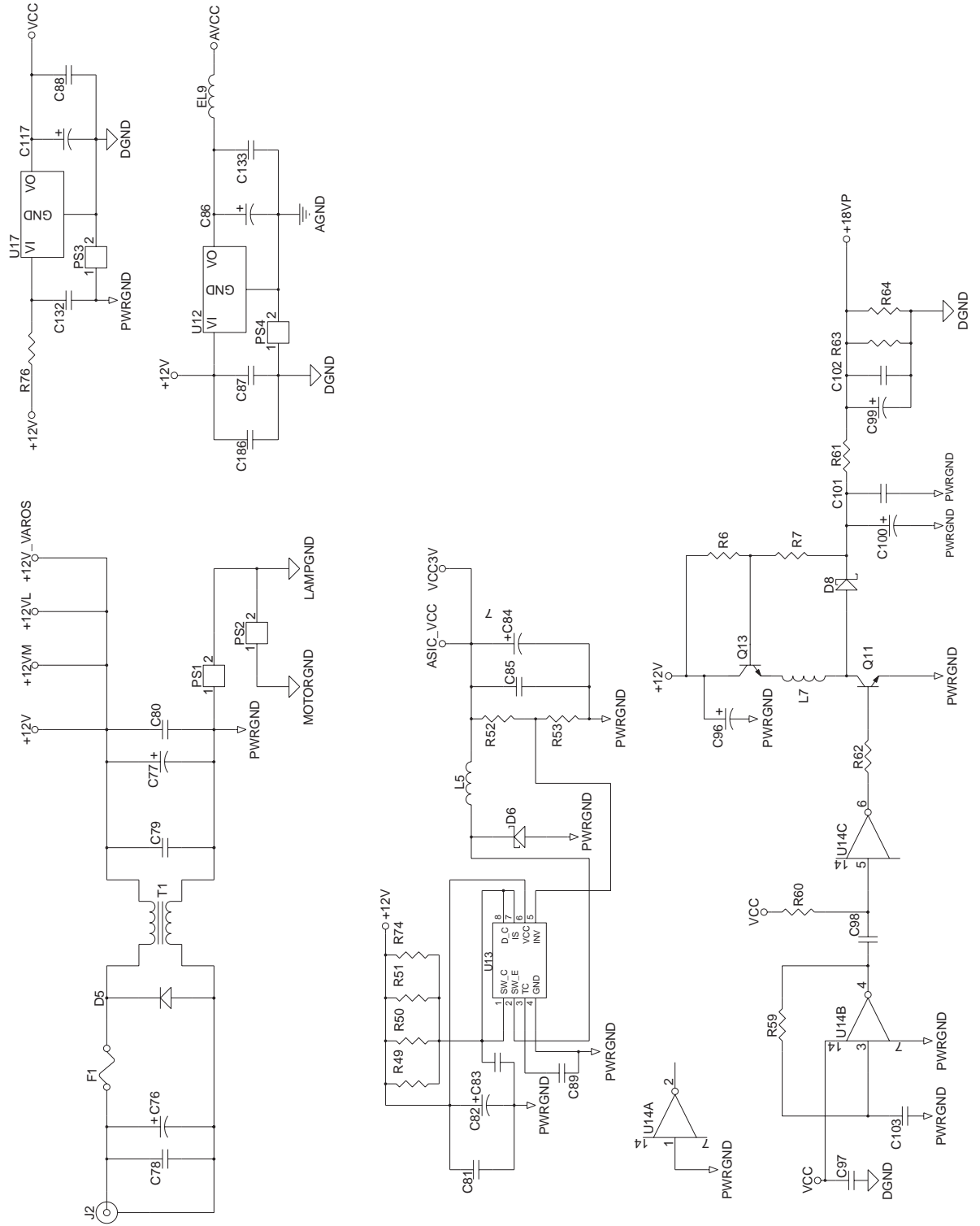

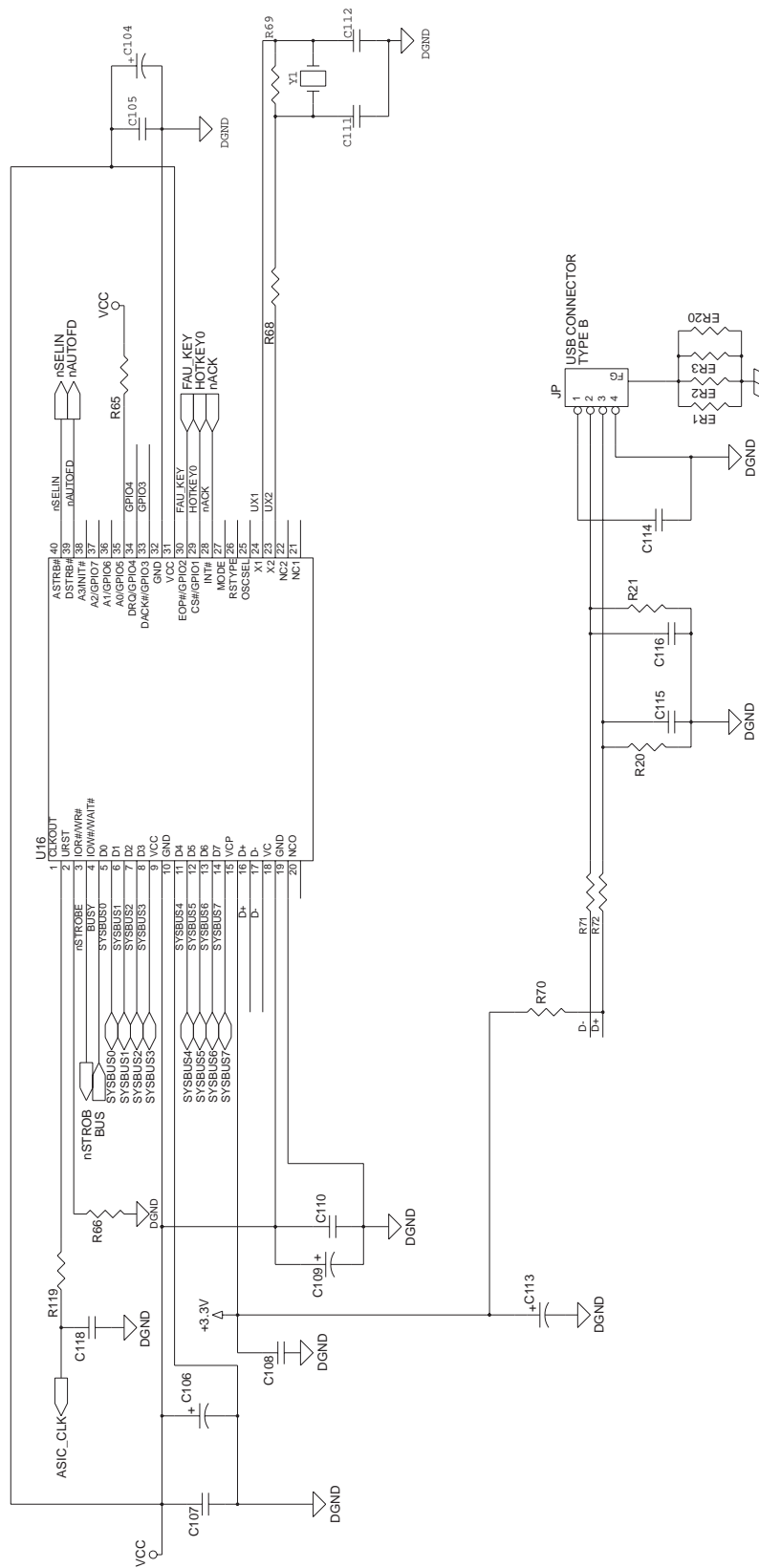

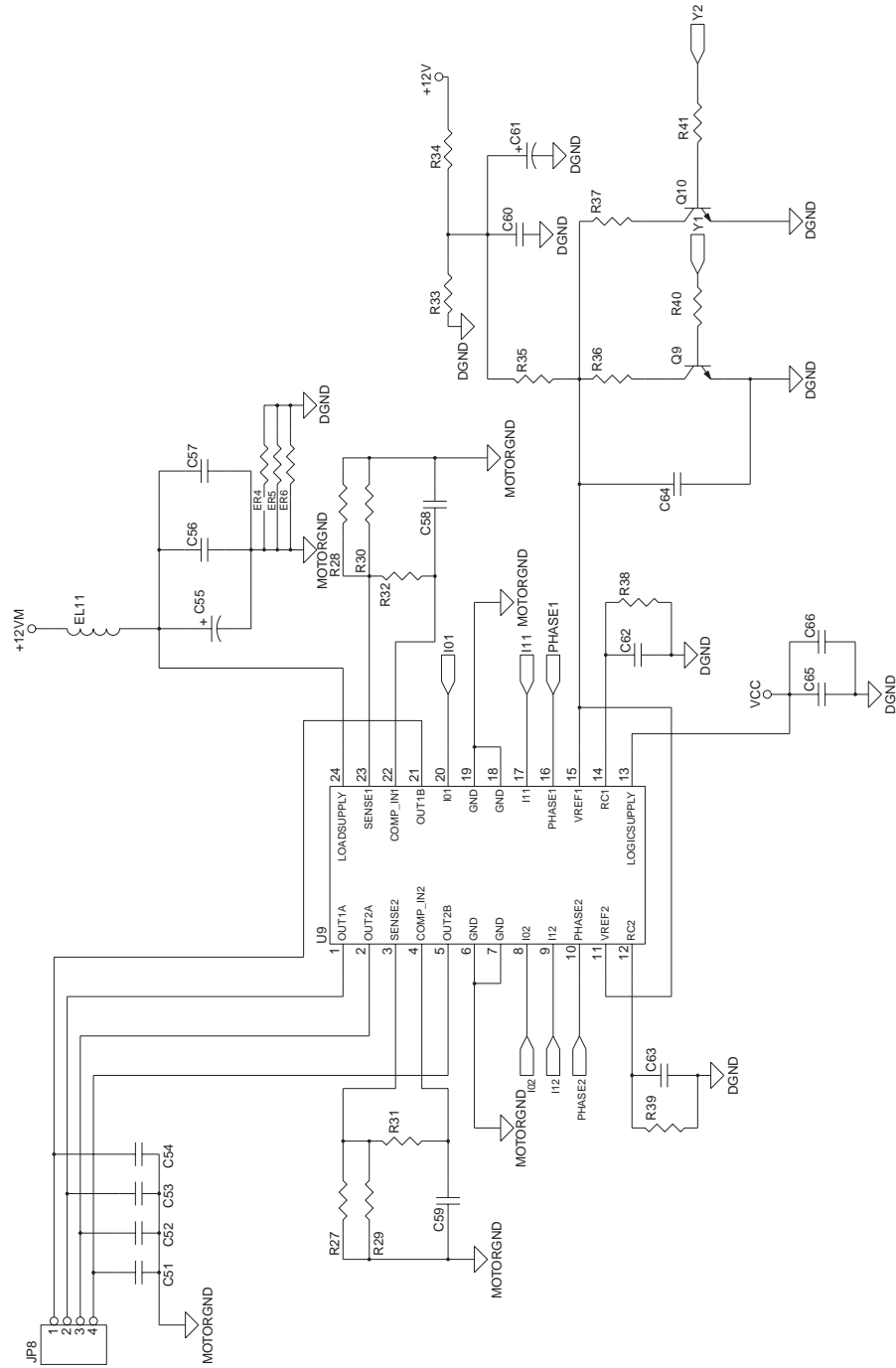

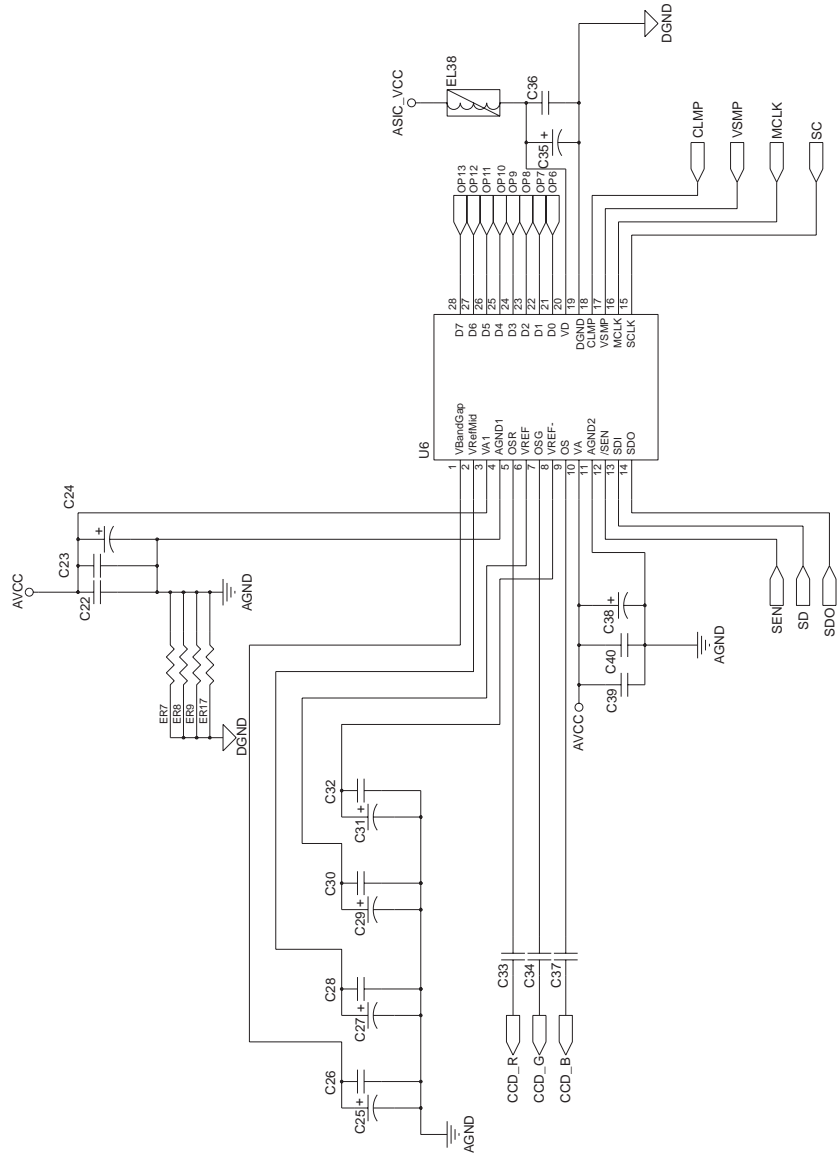

IV. MAIN PCB CIRCUIT DIAGRAM (CanoScan D2400U)

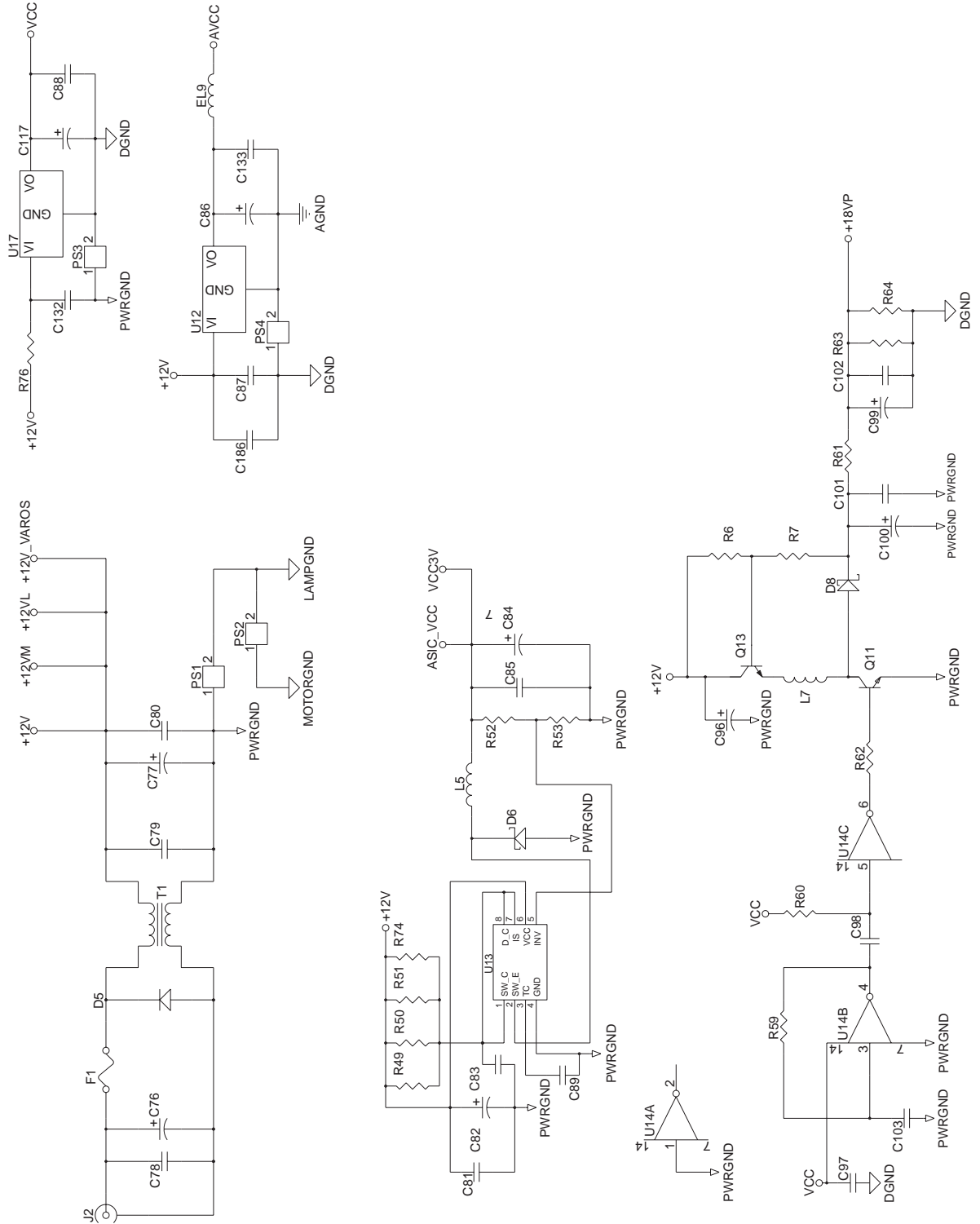

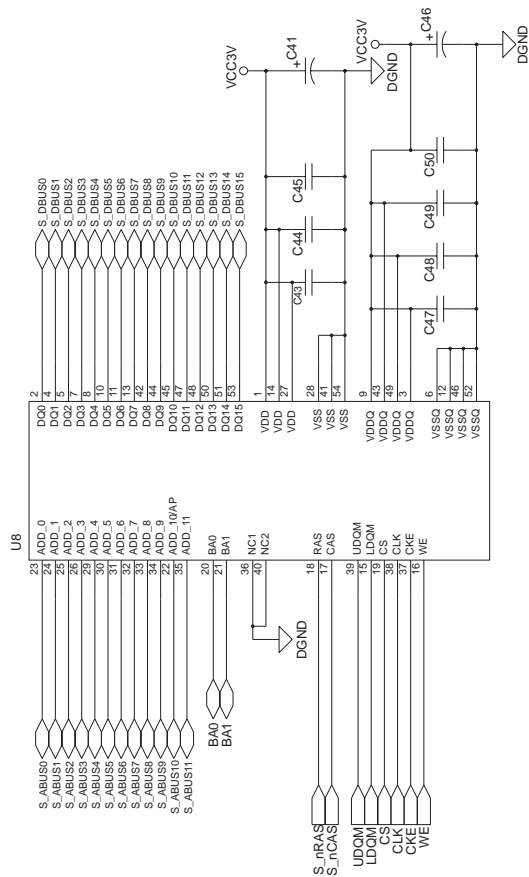
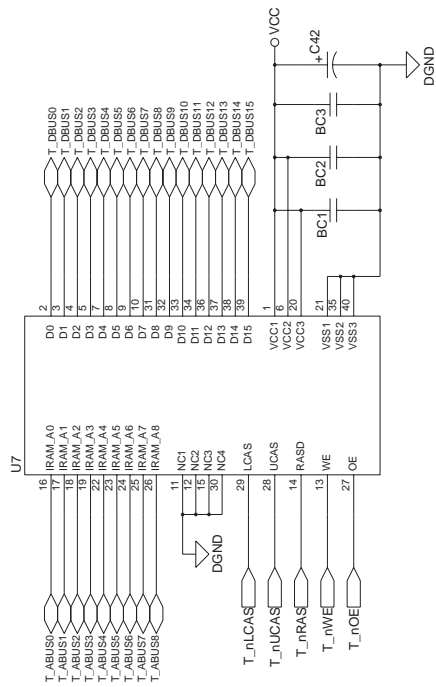

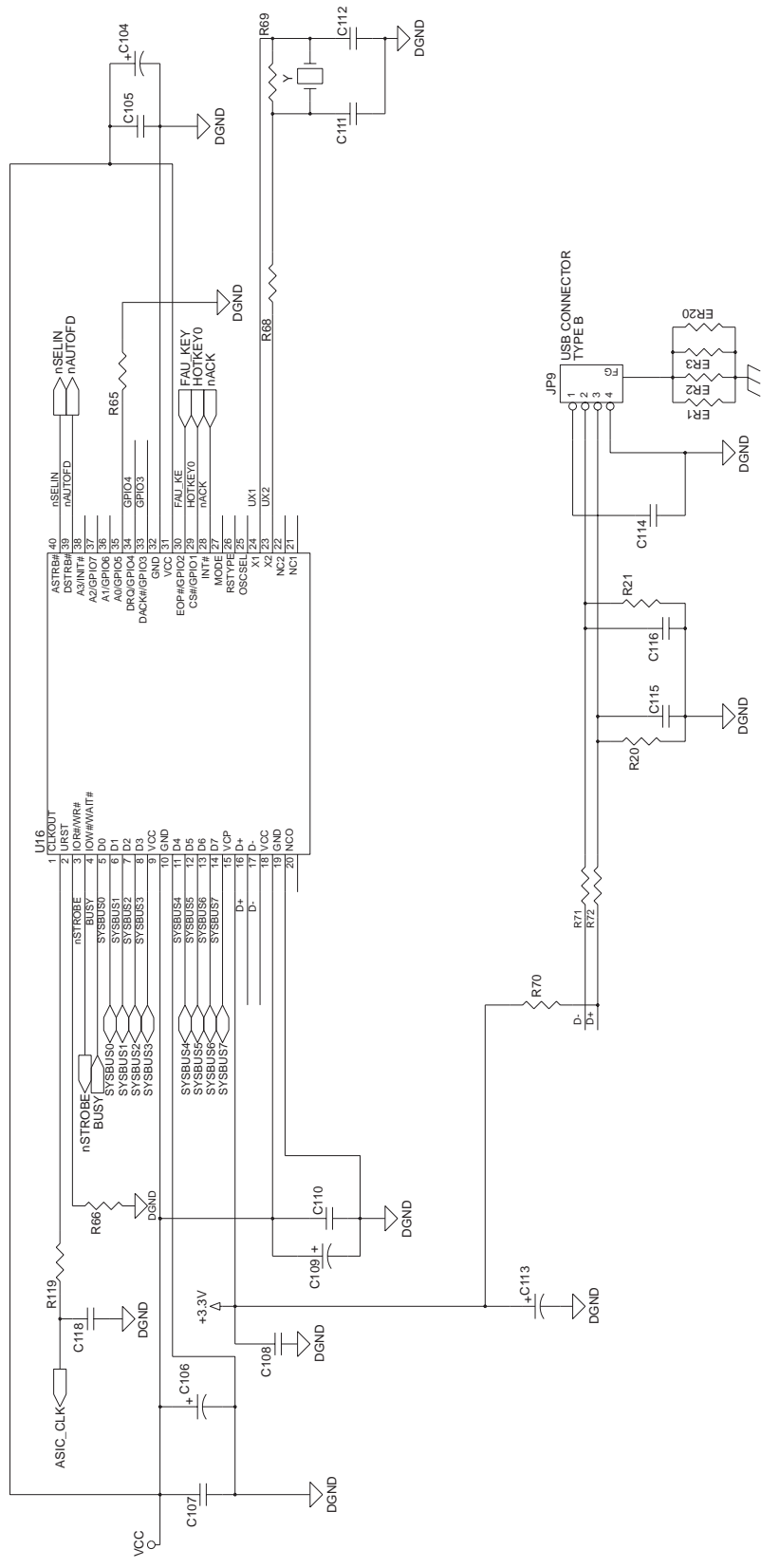

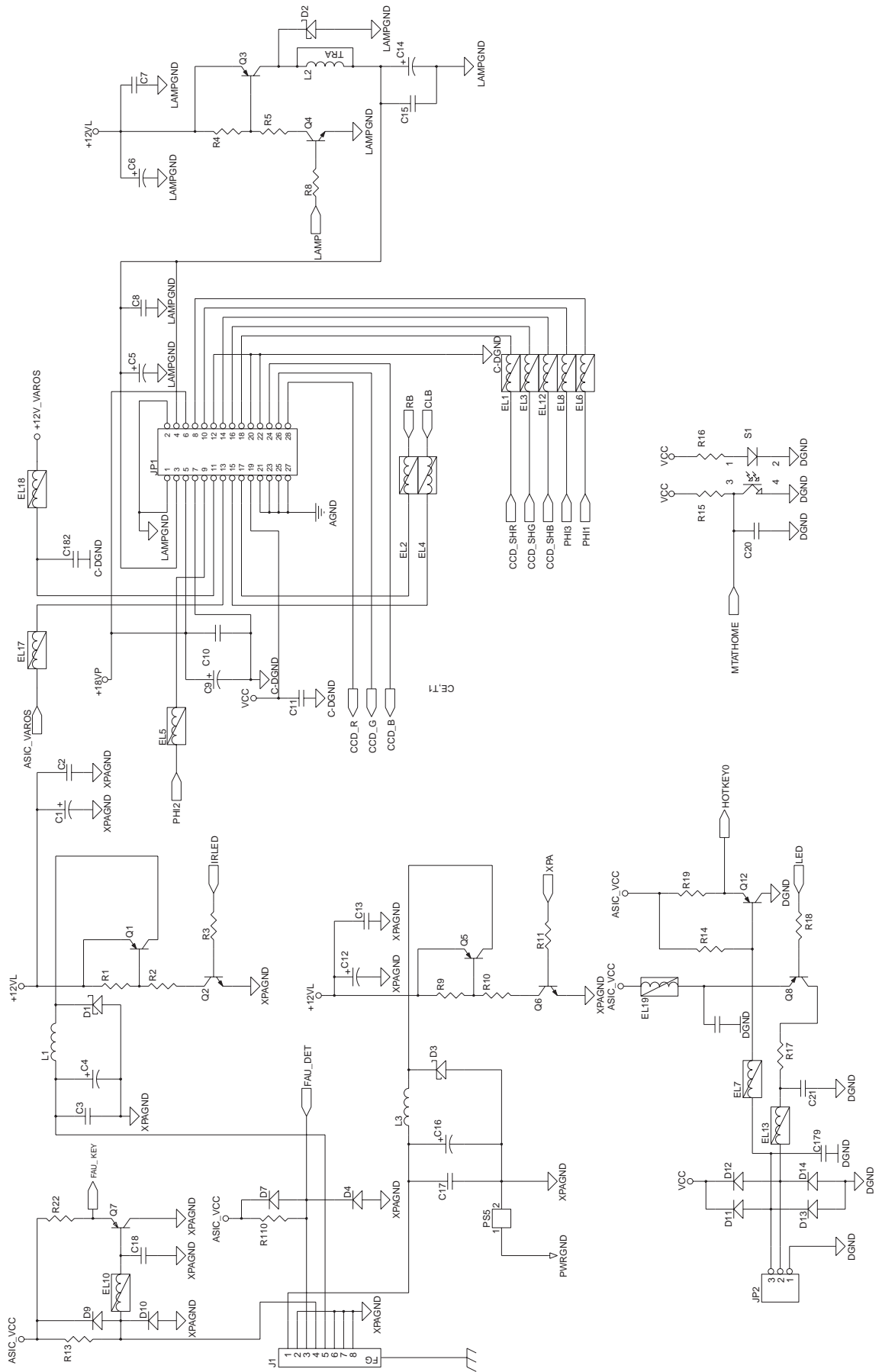

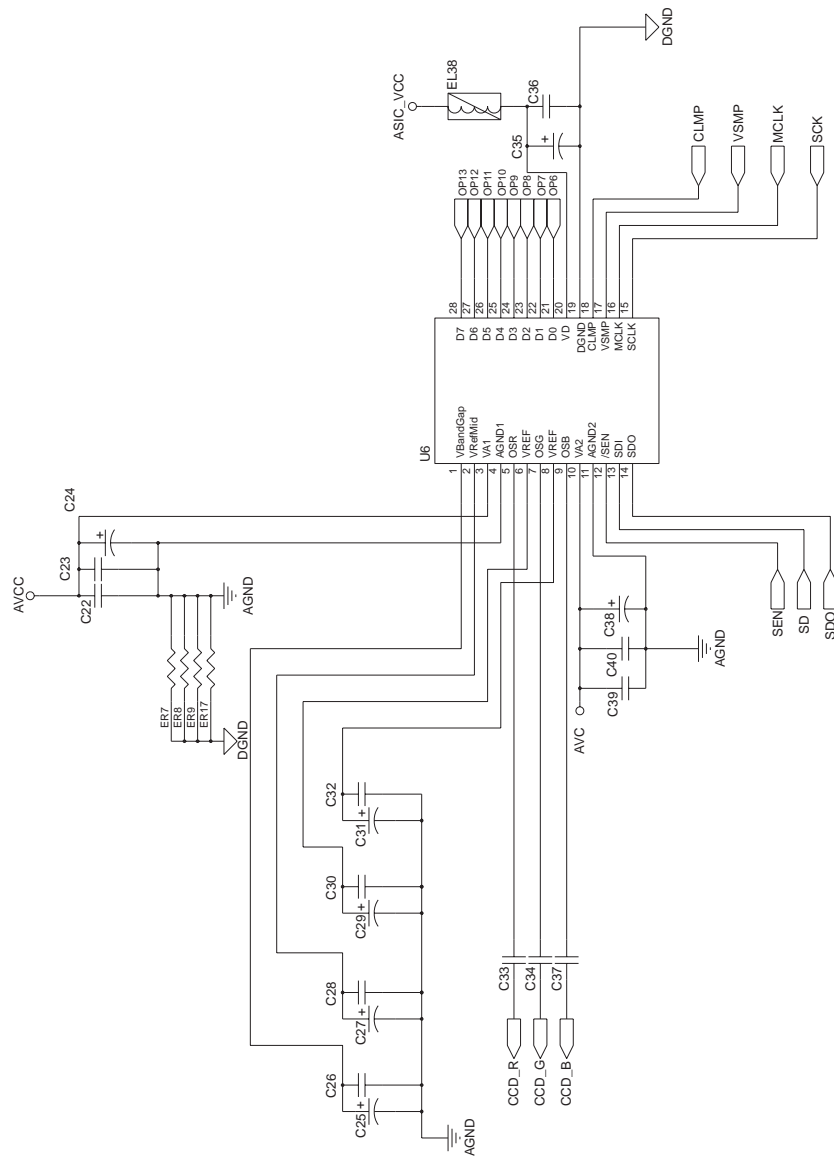

Canon